

45T – “MC”, “PG”, “PF”, “PB” Patent pending

ELEMENTO ELASTICO A ROTAZIONE A MOLLA – “MC”, “PG”, “PF”, “PB” Patent pending – TENDICATENA AUTOMATICO – TENDICINGHIA AUTOMATICO – GRUPPO DI PRESSIONE A ROTAZIONE

Principali caratteristiche: Struttura in alluminio pressofuso, Superfici lisce, Versatile, Poliedrico, Rotazione $\pm 45^\circ (\pm 60^\circ)$, Carico sviluppato proporzionale alla rotazione, Molle ingrassate, Innovativi sistemi di personalizzazione.

Gli articoli di Tecnidea Cidue 45T sono elementi elastici con funzionamento a rotazione. All'interno dei due gusci uniti tra loro da una boccola centrale in acciaio sono alloggiato delle molle. La forza di spinta si crea mettendo in rotazione tra loro i due gusci. L'angolo di rotazione di lavoro è $\pm 45^\circ$ e nella grandezza 45T 1 l'angolo di rotazione massima può arrivare a $\pm 60^\circ$. L'installazione dell'elemento e l'azione di precarico avviene mediante chiave esagonale agendo sulla boccola. Il foro centrale filettato presente sulla boccola serve per il fissaggio dell'elemento elastico. La struttura in alluminio pressofuso con superfici lisce permette l'utilizzo in ambienti dove sia richiesta una particolare pulizia senza accumulo di sporco o polveri sui componenti meccanici. Il range di temperatura d'impiego è: $-30^\circ\text{C}/+130^\circ\text{C}$. Il principale settore d'impiego degli elementi elastici 45T è quello del tensionamento di catene e cinghie, pertanto nel catalogo sono riportati anche numerosi kit d'interfaccia: pattini in polietilene (tipo OVA, OVR, VR e VB), pignoni tendicatena (tipo NB, IB, KB e ZK), rulli in poliammide (tipo RP), rulli in acciaio (tipo RU), e pulegge per cinghie trapezoidali (tipo PQ). E' possibile inoltre, personalizzare l'elemento elastico 45T con degli accessori per aumentare i campi applicativi o la facilità d'impiego: piastrine anti slittamento (tipo R ed RA), sistemi di precarica (tipo PG, PF e PB), finecorsa elettrico (tipo E), un sistema per controllarne il movimento (tipo MC) e ingrassatore (tipo G). Numerose proposte illustrate nel catalogo sono innovative e consentono di migliorare lo sviluppo tecnologico di questo settore anche ampliandone le soluzioni tecnico-applicative.

ELASTIC ELEMENT WITH SPRING ROTATION – “MC”, “PG”, “PF”, “PB” Patent pending – AUTOMATIC CHAIN-TIGHTENER – AUTOMATIC BELT-TIGHTENER – ROTATIONAL PRESSURE UNIT

Main features: Structure made of die-cast aluminium, Smooth surfaces, Versatile, Polyhedral, Rotation $\pm 45^\circ (\pm 60^\circ)$, produced Load proportional to the rotation, Greased springs, Innovative customization systems.

The Tecnidea Cidue 45T articles are elastic elements with rotation working. Inside the two shells fixed to each other with a steel central bush are lodged some springs. The pushing force is created by rotating the two shells among them. The working rotation angle is $\pm 45^\circ$ and in the size 45T 1 the maximum rotation angle can reach the $\pm 60^\circ$. The element installation and the preloading operation occur with an hexagonal wrench acting on the bush. The central threaded hole on the bush is to assembly of the elastic element. The die-cast aluminium structure with smooth surfaces allows the use in places where a particular cleanliness is required without the accumulation of dirt or powders on the mechanical components. The working temperature range is: $-30^\circ\text{C}/+130^\circ\text{C}$. The elastic elements 45t find their main utilization in the field of belt- and chain-stretching, therefore in the catalogue are also reported the many interface kits: polyethylene sliding block (type OVA, OVR, VR and VB), sprocket wheelset (type NB, IB, KB and ZK), rollersets in polyamide (type RP), rollersets in steel (type RU), and pulleys for V-belts (type PQ). It is also possible to customize the elastic element 45T with some accessories to increase the application fields or the easy of use: anti-sliding plates (type R and RA), preloading systems (type PG, PF and PB), travel-end switch (type E), a system to control the movement (type MC) and greaser (type G). Many proposals showed in the catalogue are innovative and they allow the technological development of this sector also extending the technical and application solutions.

GENERAL TERMS OF SALE:

- 1) **ORDERS** – Orders of standard and special materials must always be referred to TECNIDEA CIDUE S.r.l. offers. Orders are binding for clients. Once the manufacturing has started, any cancellations or reductions won't be accepted, excepting indemnity of manufacturing and material costs met up to cancellation, which will be in any case quantified by TECNIDEA CIDUE S.r.l.
- 2) **PRICES** – Only the effective prices at order-date are valid. All prices have to be understood Ex-Factory, excluding packing. In case of possible increases of manufacturing costs, materials and so on, between the date of our order-confirmation and completing of order, TECNIDEA CIDUE S.r.l. can adapt the prices, also for pending orders, to the occurred increases.
- 3) **DELIVERY TERMS** – Only the delivery time stated by TECNIDEA CIDUE S.r.l. are valid. However they are only approximate. In cases of difficulties in supply of raw materials, strikes, or circumstances beyond our control, delivery times are automatically deferred with no obligation on TECNIDEA CIDUE S.r.l. to indemnify the customer in any case. The customer must collect the ordered material when it gets ready.
- 4) **DISPATCH** – The shipment of goods, including freight free deliveries, is went at the purchaser's own risk. If the quantity of the goods is inferior to the ordered ones, TECNIDEA CIDUE S.r.l. must be informed within eight (8) days from the receipt of the goods. If transport freight are charged, even if partially, by TECNIDEA CIDUE S.r.l., TECNIDEA CIDUE S.r.l. reserves the right to choose the less expensive means of conveyance.
- 5) **PACKING** – Packing is charged at cost.
- 6) **RETURNED GOODS** – TECNIDEA CIDUE S.r.l. doesn't accept previously unauthorised returned goods. Returned goods have to be free warehouse, packing and clearance included. The 15% of the value of the returned goods will be charged you to recover the storage and bookkeeping costs.
- 7) **WARRANTY** – Messrs TECNIDEA CIDUE S.r.l. undertakes to repair or replace, freely, the pieces TECNIDEA CIDUE S.r.l. recognizes as faulty. Defective goods have to be returned to the base of too free warehouse, packing and clearance included. The warranty decays when pieces returned as faulty have been repaired or tampered with. Repairing of defective pieces made by the buyer will be recognized only if authorised by TECNIDEA CIDUE S.r.l. and after its approval of the estimate of expenditure. TECNIDEA CIDUE S.r.l. doesn't take the responsibility and doesn't recognize any indemnity for possible damages, which occurred during the use of its products, even if defective.
- 8) **RESPONSIBILITY** - TECNIDEA CIDUE S.r.l. doesn't take the responsibility and doesn't recognize any indemnity for possible damages, which would occur during the use of its products, even if defective. TECNIDEA CIDUE S.r.l. declines all responsibility for the execution of details on customer's drawing, that are subjected to possible patents.
- 9) **PAYMENTS** – Only payments that have been effected according to agreed terms, will be considered valid. Once the payment terms have been expired, TECNIDEA CIDUE S.r.l. will calculate the default interests at 3% higher than the legal ones and TECNIDEA CIDUE S.r.l. has the right to demand the payment. In any case of delayed or no-payment TECNIDEA CIDUE S.r.l. reserves the right to interrupt the deliveries of the pending orders or to demand the payment in advance without any type of indemnity or compensation. The customer has to make the payment at the established date for the total amount of the invoice and without any deduction, even for claimed manufacturing or already owned materials.
- 10) **PROPERTY** – the property of delivered goods always belongs to TECNIDEA CIDUE S.r.l. up to the time of the complete payment of the invoices.
- 11) **PLACE OF JURISDICTION** – In the case of debate the Court of Verona have the exclusive jurisdiction for any commercial relations of TECNIDEA CIDUE S.r.l.

PRESENTAZIONE ARTICOLI / PRODUCT RANGE

 45T pag. 06	 R pag. 07	 RA pag. 08	 G pag. 08
 E pag. 09	 * MC pag. 10	 * PG pag. 11	 * PF pag. 12
 * PB pag. 13	 45TOVA pag. 13	 45TOVR pag. 15	 45TVB pag. 17
 45TVR pag. 19	 45TKB pag. 21	 45TZK pag. 23	 45TNB pag. 25
 45TIB pag. 26	 45TRP pag. 28	 45TRU pag. 29	 45TPQ pag. 31

- *: PATENT PENDING

© Copyright Tecnidea Cidue S.r.l. - Italy 2017

Questa pubblicazione non può essere riprodotta anche in parte senza la preventiva autorizzazione scritta di Tecnidea Cidue S.r.l.
 No part of this è publication may be reproduced by any means without the written permission of Tecnidea Cidue S.r.l.

• **Q Forza di spinta:** L'elemento elastico 45T presenta una forza di spinta proporzionale all'angolo di rotazione. Tra i due gusci sono alloggiati delle molle che vengono messe in compressione tramite la rotazione relativa delle due parti.

• **Q Pushing force:** The elastic element 45T shows a pushing force which is proportional to the rotation angle. Between the two shells are lodged some springs which are put under compression through the relative rotation of the two parts.

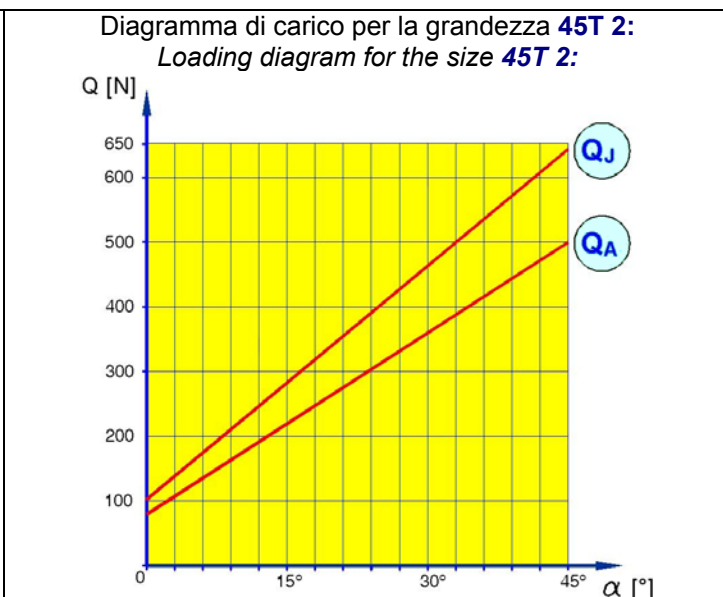
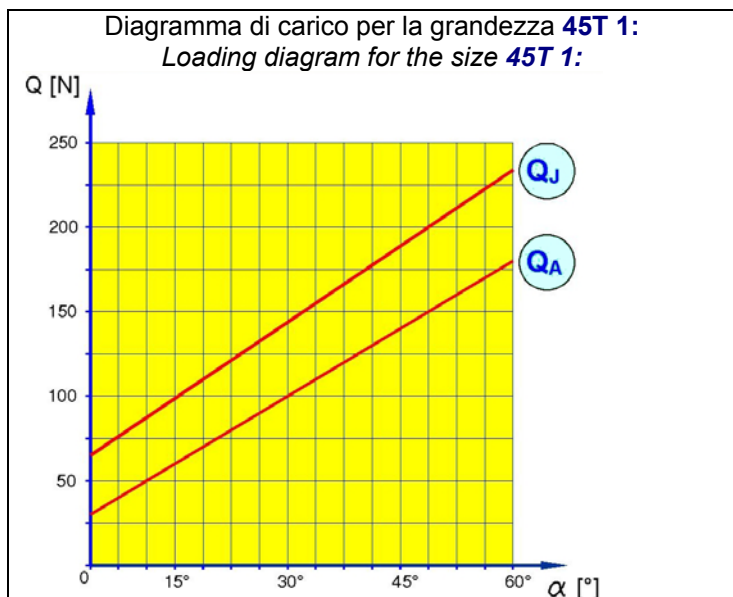

Legenda / Key :

- α : Angolo di rotazione / Rotation angle [°]
- A : Interasse A / Interaxis A [mm]
- J : Interasse J / Interaxis J [mm]
- Q_A : Forza A / Force A [N]
- Q_J : Forza J / Force J [N]
- T_A : Corsa A / Travel A1 [mm]
- T_J : Corsa J / Travel J [mm]

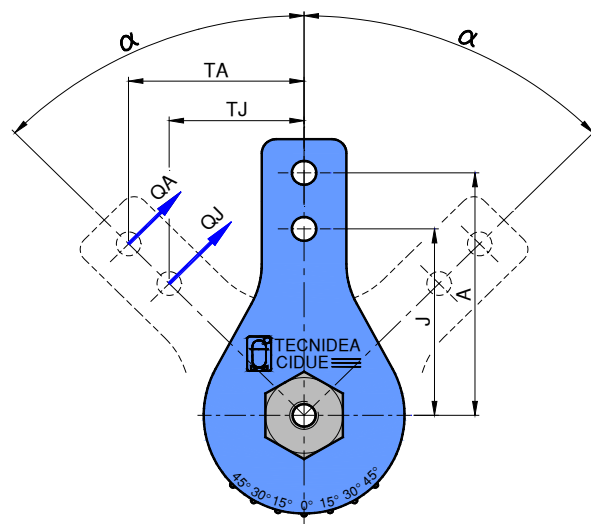

45T 1

α	A	T_A	Q_A	J	T_J	Q_J
15°	86.5	22.4	50	66.5	17.2	65
30°	86.5	43.2	100	66.5	33.2	142
45°	86.5	61.2	140	66.5	47.0	185
60°	86.5	74.9	180	66.5	57.6	234

45T 2

α	A	T_A	Q_A	J	T_J	Q_J
15°	100	25.9	220	78	20.2	282
30°	100	50.0	360	78	39.0	461
45°	100	70.7	500	78	55.1	640

• **Informazioni tecniche / Technical information:**

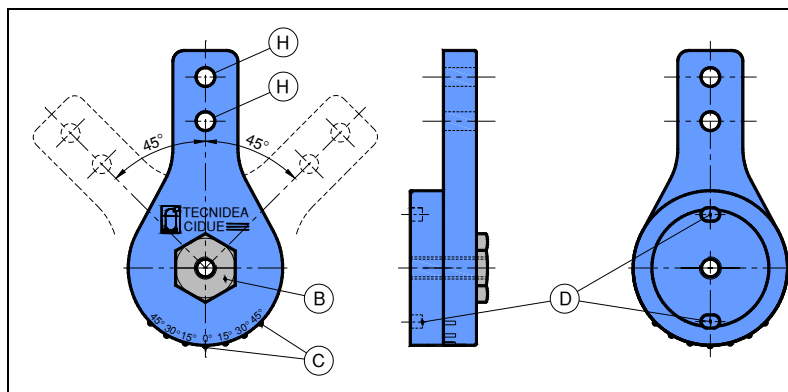

- H: Fori di posizionamento kit.
- B: La boccia centrale può essere utilizzata per precaricare l'elemento elastico in fase di montaggio in entrambi i sensi di rotazione mediante una chiave inglese.
- C: Sull'elemento elastico sono presenti delle tacche di riferimento angolare che permettono sia di visualizzare la rotazione in fase di precarica sia di controllare l'allungamento della catena (o della cinghia) durante il lavoro.
- D: Nicchie di alloggiamento spine di reazione per evitare eventuali slittamenti.
- H: Kit positioning holes.
- B: The central bush can be used to preload the elastic element during the installation in both directions through a spanner.
- C: On the elastic element there are some angular reference notches which allow both to visualize the rotation during the preload phase and to check the elongation of the chain (or of the belt) during the work.
- D: Slot niches reaction pins to avoid possible slippings.

• Istruzioni di montaggio: / *Assembly Instruction:*

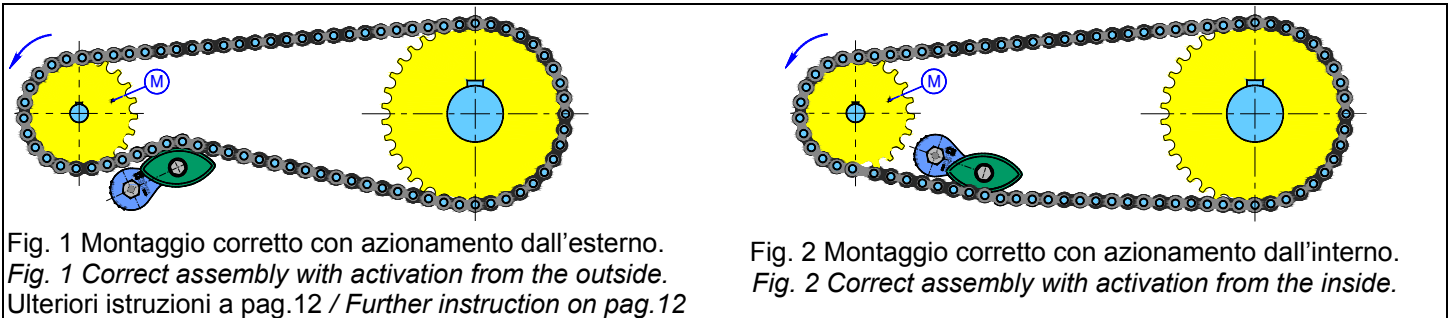

A) Montaggio su piastra passante: / *Assembly on passing plate:*

1) Con vite F di fissaggio lenta, il tenditore va posizionato sul tratto lento della trasmissione il più vicino possibile al pignone motore M. / *With slow fixing screw F, the tightener must be positioned on the slow section of the transmission, as closer as possible to the motor sprocket M.*

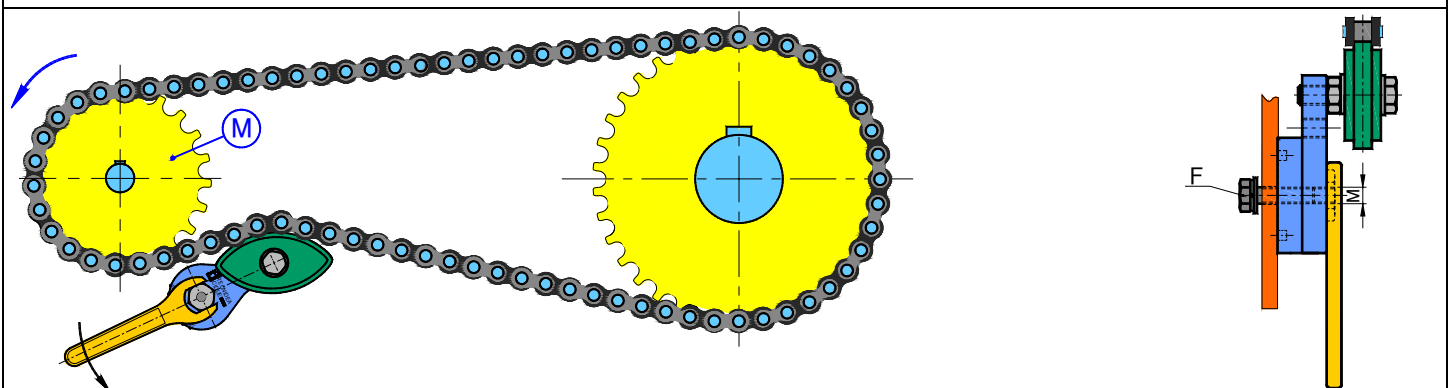

2) Mantenendo la vite di fissaggio F lenta, con l'aiuto di una chiave inglese caricare il tenditore fino all'angolo di rotazione desiderato. Successivamente stringere la vite di fissaggio F. / *Keeping the slow fixing screw F, with the help of a spanner load the tightener until the desired rotation angle. Tighten then the fixing screw F.*

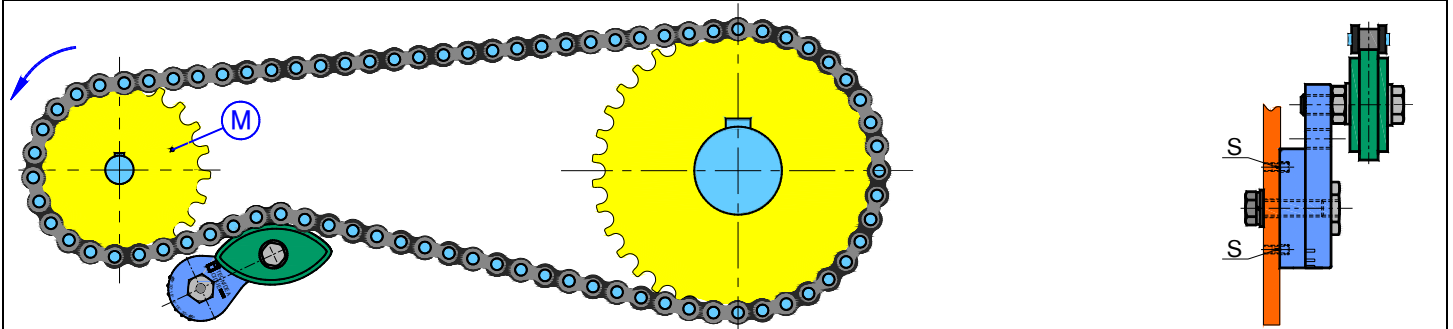

3) Dopo il fissaggio della vite M, Per evitare eventuali slittamenti, si può inserire una spina di reazione in una delle nicchie di alloggiamento S. / *After the fixing of the M screw, in order to avoid possible slippings, one reaction pin may be inserted in the S slot niches.*

B) Montaggio su piastra cieca: / *Assembly on blind plate:*

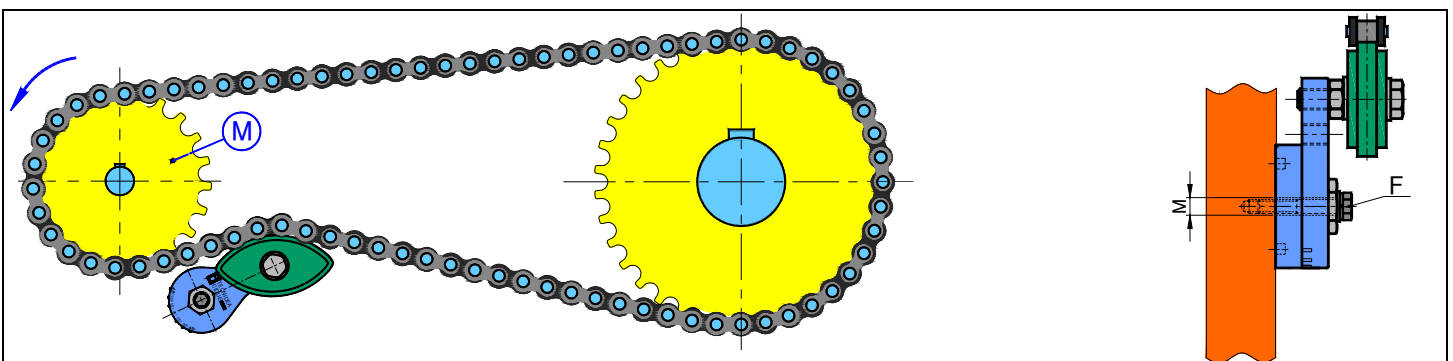

4) Per un montaggio frontale (ad esempio su piastre "cieche") si possono seguire le istruzioni 1 e 2, ma utilizzando una vite di fissaggio F con dimensione minore del foro filettato M della boccia centrale.
For a central assembly (for example on "blind" plates) instructions 1 and 2 can be followed, but using a fixing screw F with a smaller size than the threaded hole M of the central bush.

Elementi elastici a rotazione - Tipo: **45T** / Rotating elastic elements - Type: **45T**



MATERIALI Alluminio. Molle e boccola di scorrimento in acciaio.

TRATTAMENTI Particolari in alluminio sabbiati. Boccola zincata. Molle grezze ingrassate.

IMPIEGO Elemento elastico a rotazione generalmente utilizzato come tendicatena/tendinghia o gruppo di pressione. Angolo di rotazione di lavoro: $\pm 45^\circ$. I fori H consentono il posizionamento dei kit sui bracci A ed J a seconda del carico desiderato. Campo d'impiego: $-30^\circ\text{C}/+130^\circ\text{C}$.

MATERIALS: Cast aluminium. Springs and exagonal bush are made by steel.

TREATMENTS Aluminium parts are sandblasted. Bush is zinc plated. Springs are in rough greased steel.

USE Rotating elastic element normally used as chain/belt tensioner or down-holder/pressure unit. Working rotational angle: ± 45 . The holes H allow the positioning of the kits on the arms A and J depending on the desired load. Application range: $-30^\circ\text{C} / +130^\circ\text{C}$.

Esecuzione / Esecution:

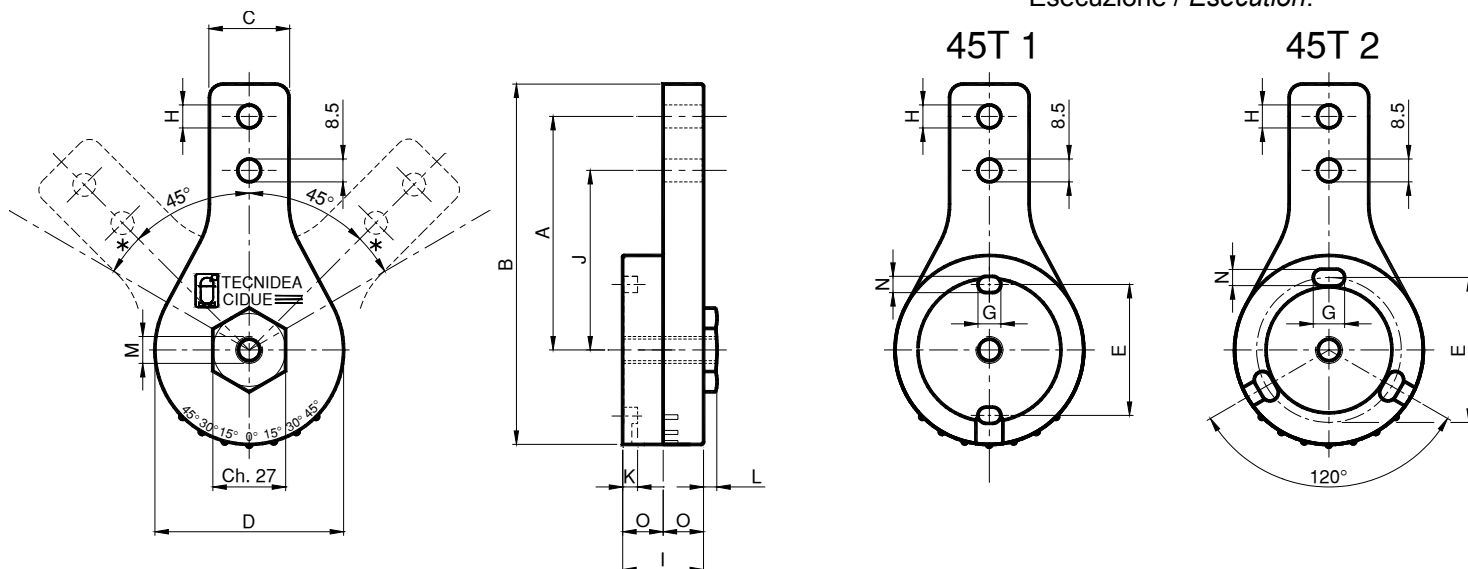

*= 45T 1: Angolo di rotazione max: $\pm 60^\circ$ / 45T 1: Maximum rotational angle: $\pm 60^\circ$

Tipo Type	Cod. N°	A	B	C	D	E	G	H	I	J	K	L	M	N	O	Newton QA max	Newton QJ max	Peso Weight in Kg
45T 1-8	AS010900	86.5	133.5	29.5	70	48.5	8.5	8.5	30	66.5	5.5	5	M10	6	15	180	234	0.35
45T 1-10	AS010901	86.5	133.5	29.5	70	48.5	8.5	10.5	30	66.5	5.5	5	M10	6	15	180	234	0.35
45T 1-M10	AS010902	86.5	133.5	29.5	70	48.5	8.5	M10	30	66.5	5.5	5	M10	6	15	180	234	0.35
45T 1-12	AS010903	86.5	133.5	29.5	70	48.5	8.5	12.5	30	66.5	5.5	5	M10	6	15	180	234	0.35
45T 1-M12	AS010904	86.5	133.5	29.5	70	48.5	8.5	M12	30	66.5	5.5	5	M10	6	15	180	234	0.35
45T 1-M16	AS010907	86.5	133.5	29.5	70	48.5	8.5	M16	30	66.5	5.5	5	M10	6	15	180	234	0.35
45T 2-10	AS010910	100	160	34	90	69	15	10.5	36	78	7.5	7	M12	8	18	500	640	0.89
45T 2-M10	AS010911	100	160	34	90	69	15	M10	36	78	7.5	7	M12	8	18	500	640	0.89
45T 2-12	AS010912	100	160	34	90	69	15	12.5	36	78	7.5	7	M12	8	18	500	640	0.89
45T 2-M12	AS010913	100	160	34	90	69	15	M12	36	78	7.5	7	M12	8	18	500	640	0.89
45T 2-16	AS010915	100	160	34	90	69	15	16.5	36	78	7.5	7	M12	8	18	500	640	0.89
45T 2-M16	AS010916	100	160	34	90	69	15	M16	36	78	7.5	7	M12	8	18	500	640	0.89
45T 2-20	AS010919	100	160	34	90	69	15	20.5	36	78	7.5	7	M12	8	18	500	640	0.89
45T 2-M20	AS010920	100	160	34	90	69	15	M20	36	78	7.5	7	M12	8	18	500	640	0.89

Montaggio: il tenditore può essere fissato su entrambi i lati. Le istruzioni di montaggio sono illustrate a pag.5 .

Installation: the tightener can be fixed on both sides. The assembly instructions are illustrated on page 5 .

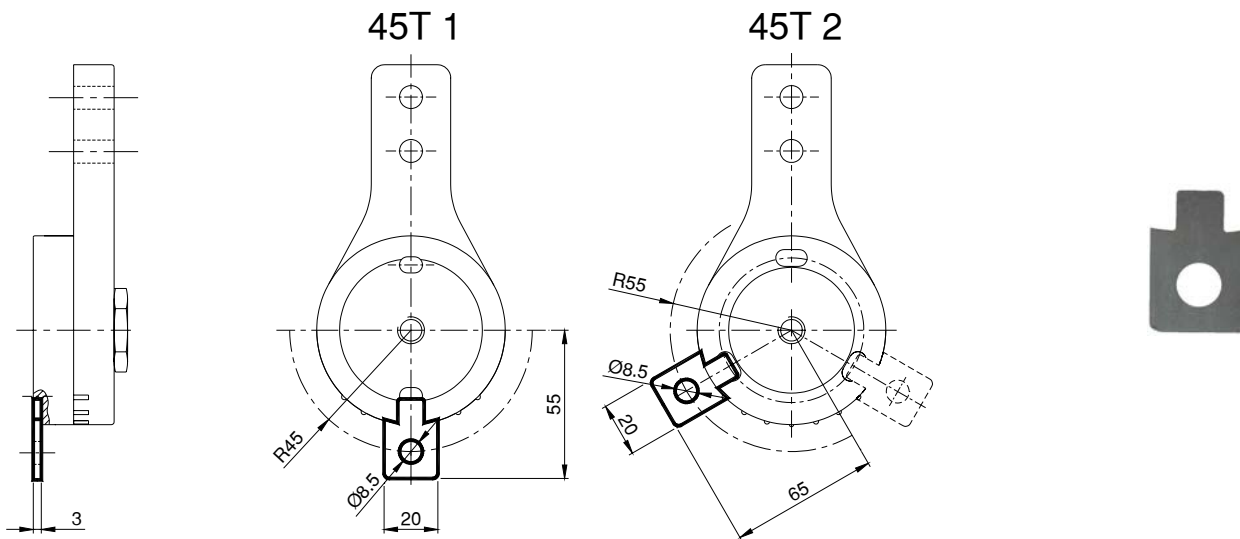
Antirotazione – Tipo: R / *Antirotation – Type: R*Esecuzione / *Esecution:* **MATERIALI** Acciaio.**TRATTAMENTI** Zincatura elettrolitica.**IMPIEGO** L'accessorio antirotazione R viene utilizzato per fissare l'elemento elastico ed evitare che possa slittare durante il funzionamento. L'accessorio si inserisce all'interno della cava già predisposta sulla base dell'elemento elastico.

Per ordine: Tipo R1 Cod. n° AS011200

Tipo R2 Cod. n° AS011201

MATERIALS Steel.**TREATMENTS** Electrolytic zinc plated.**DUTY** The R anti-rotation accessory is used to fix the elastic element and to prevent it from sliding during operation. The accessory fits into the already arranged space on the basis of the elastic element.

In order: Type R1 Cod. n° AS011200

Type R2 Cod. n° AS011201

Esempio di ordinazione:

Tutti gli accessori o personalizzazioni (riportati nel catalogo da pagina 7 a pagina 11) devono essere ordinati abbinati ad un elemento elastico 45T di pagina 6 o ad un elemento tendicatena/tendinghia riportati nel catalogo da pagina 12 a pagina 31.

Esempio 1:

45T 1-M10 R1 (AS010902 + AS011200)

Ovvero un elemento elastico semplice con accessorio antislittamento.

Esempio 2:

45T1OVA3S G (AS010902 + AS010931 + AS011240)

Ovvero un elemento tendicatena con pattino ovale per catena 08-B1 e ingrassatore.

Order example:

All the accessories or customizations (reported in the catalogue from page 7 to page 11) have to be ordered coupled with a 45T elastic element on page 6 or with a chain- or belt-tightener element reported in the catalogue from page 12 to page 25.

*Example 1:**45T 1-M10 R1 (AS010902 + AS011200)**Namely a simple elastic element with anti-sliding accessory.**Example 2:**45T1OVA3S G (AS010902 + AS010931 + AS011240)**Namely a chain tightener element with sliding block with oval form for chain with pitch 08-B1 and greaser.*

Antirotazione con asola – Tipo: **RA** / *Antirotation with slot – Type: RA*

Esecuzione / *Esecution:*

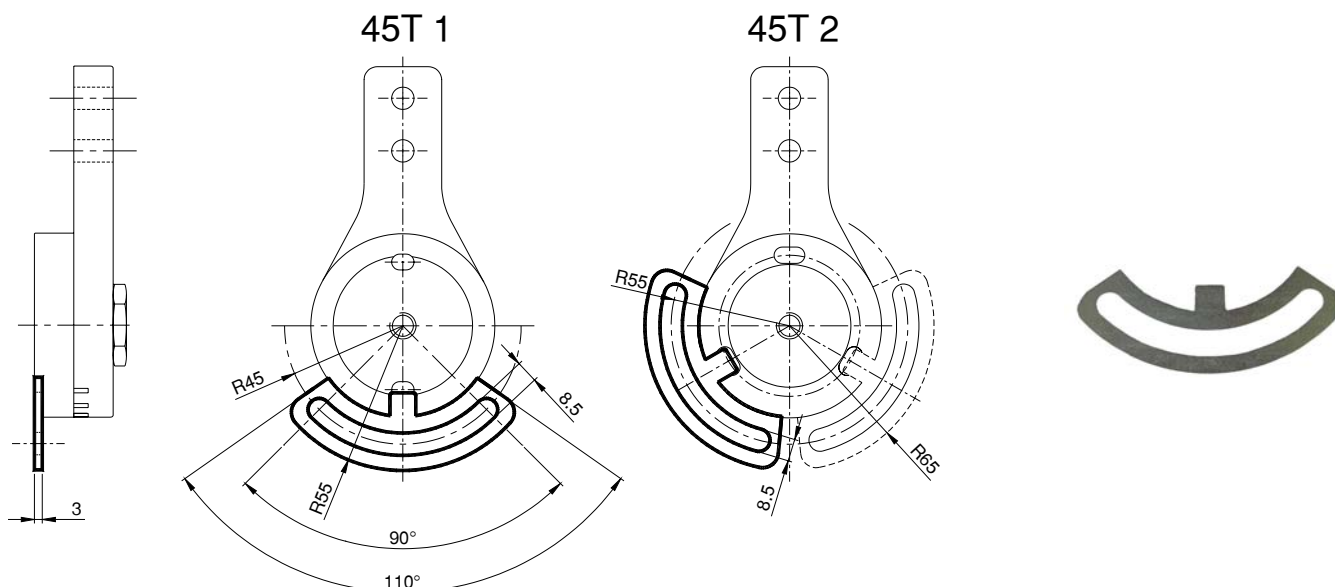

MATERIALI Acciaio.

TRATTAMENTI Zincatura elettrolitica.

IMPIEGO L'accessorio antirotazione **RA** viene utilizzato per fissare l'elemento elastico ed evitare che possa slittare durante il funzionamento. L'accessorio si inserisce all'interno della cava già predisposta sulla base dell'elemento elastico. Il particolare disegno di questo accessorio permette un fissaggio lungo tutta l'asola.

Per ordine: Tipo **RA1** Cod. n° AS011205

Tipo **RA2** Cod. n° AS011206

MATERIALS Steel.

TREATMENTS Electrolytic zinc plated.

DUTY The **RA** anti-rotation accessory is used to fix the elastic element and to prevent it from sliding during operation. The accessory fits into the already arranged space on the basis of the elastic element. The particular drawing of this accessory allows a fixing along the whole slot.

In order: Type **RA1** Cod. n° AS011205

Type **RA2** Cod. n° AS011206

Ingrassatore – Tipo: **G** / *Greaser – Type: G*

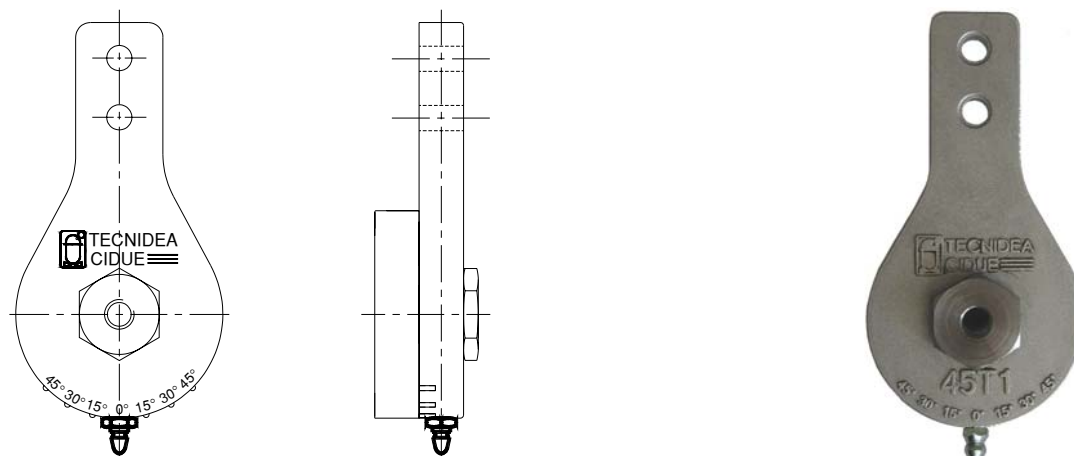

MATERIALI Acciaio.

TRATTAMENTI Zincatura elettrolitica.

IMPIEGO L'accessorio ingrassatore **G** consente di lubrificare le molle del tenditore.

Per ordine: Tipo **G1** Cod. n° **AS011240**

Tipo **G2** Cod. n° **AS011241**

MATERIALS Steel.

TREATMENTS Electrolytic zinc plated.

DUTY The greaser accessory **G** allows to grease the tightener springs.

In order: Type **G1** Cod. n° **AS011240**

Type **G2** Cod. n° **AS011241**

Finecorsa elettrico – Tipo: **E** / *Travel-end switch* – Type: **E**

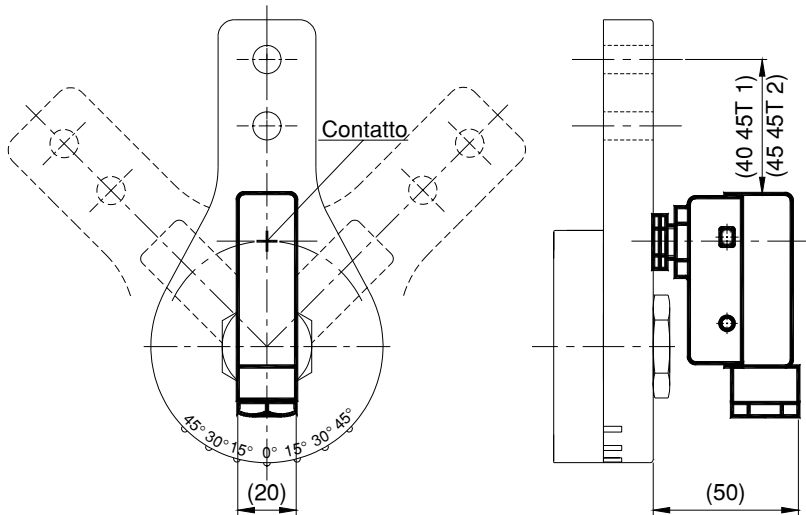

IMPIEGO Il finecorsa elettrico **E** consente di controllare e verificare il corretto funzionamento delle macchine, ma anche di ricevere o di dare dei segnali di comando per l'espletamento di funzioni meccaniche, inoltre è particolarmente utile quando si voglia garantire l'integrità della macchina e/o salvaguardare l'incolumità degli operatori.

Per ordine: Tipo **E1** Cod. n° **AS011230**
Tipo **E2** Cod. n° **AS011231**

DUTY The travel-end switch **E** allows to control and to check the correct functioning of the machines, but also to receive or to give control signals for the carrying out of the mechanical functions, moreover it is particularly useful when you want to grant the integrity of the machine and /or where the workers' safety must be protected.

In order: Type **E1** Cod. n° **AS011230**
Type **E2** Cod. n° **AS011231**

Funzionamento: / *Functioning:*

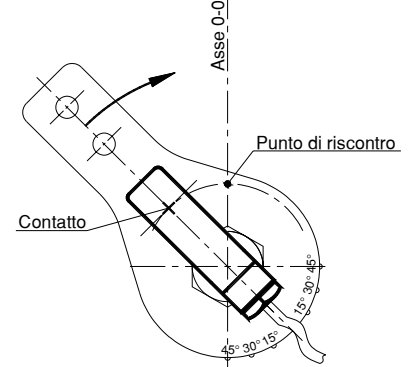

Il contatto avviene quando il sensore ed il punto R di riscontro combaciano.
The contact occurs when the sensor and the point R correspond.

Posizioni di montaggio: / *Mounting positions:*

<p>fig. 1: POS A</p>	<p>fig. 2: POS B</p>	<p>fig. 3: POS C</p>
<p>fig. 4: POS D</p>	<p>Schema elettrico: / <i>Electrical diagram:</i></p> <p>fig. 5</p>	

PATENT PENDING

Movimento controllato – Tipo: **MC** / *Controlled movement* – Type: **MC**

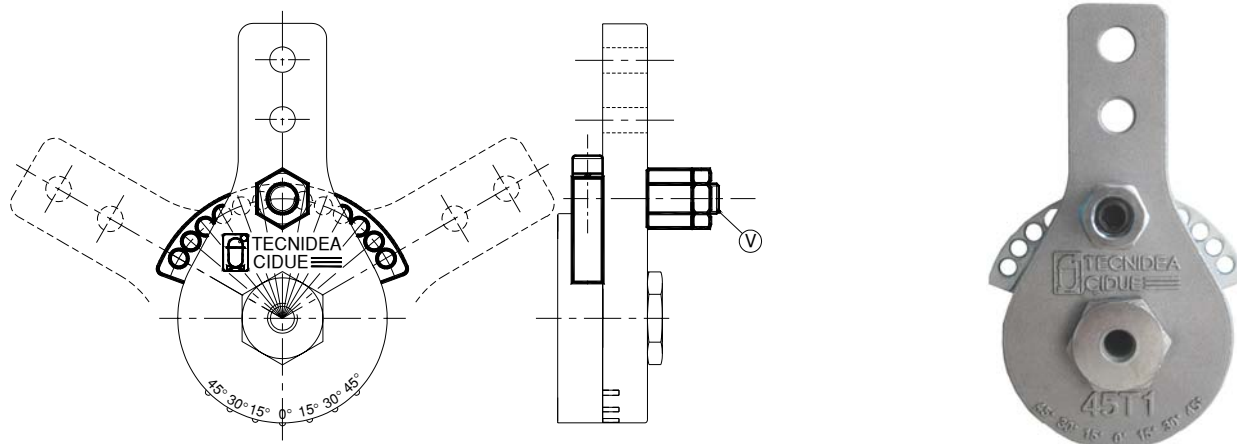

MATERIALI Acciaio.

TRATTAMENTI Zincatura elettrolitica.

IMPIEGO L'accessorio **MC** permette di controllare il movimento dell'elemento elastico in maniera graduale. La rotazione è subordinata alla forza di ritenuta fra uno scatto e l'altro ogni 10°.

Per ordine: Tipo **MC1** Cod. n° **AS011235**

Tipo **MC2** Cod. n° **AS011236**

MATERIALS Steel

TREATMENTS Electrolytic zinc plated.

DUTY The accessory **MC** allows to control the movement of the elastic element gradually. The rotation is subject to the holding force between a release and another every 10°.

In Order: Type **MC1** Cod. n° **AS011235**

Type **MC2** Cod. n° **AS011236**

Sistema di precarica con grano – Tipo: **PG** / *Preloading system with grub screw* – Type: **PG**

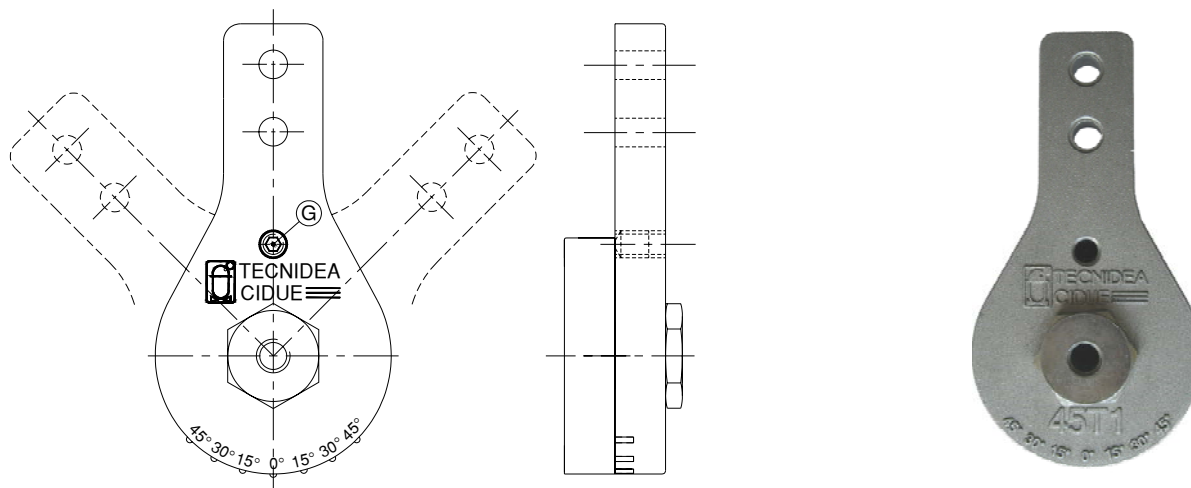

IMPIEGO Il sistema di precarica **PG** permette agendo sul grano G di bloccare l'elemento elastico all'angolo di rotazione desiderato. Dopo l'installazione il grano G va allentato per poter far lavorare l'elemento elastico.

Per ordine: Tipo **PG1** Cod. n° AS011210

Tipo **PG2** Cod. n° AS011211

DUTY The **PG** preloading system allows, acting on the preloading screw, to block the elastic element to the rotation angle wanted. After the assembly, the G preloading screw has to be loosened in order to let the elastic element works.

In order: Type **PG1** Cod. n° AS011210

Type **PG2** Cod. n° AS011211

PATENT PENDING

Sistema di precarica con piolo – Tipo: **PF** / *Preloading system with pin* – Type: **PF**

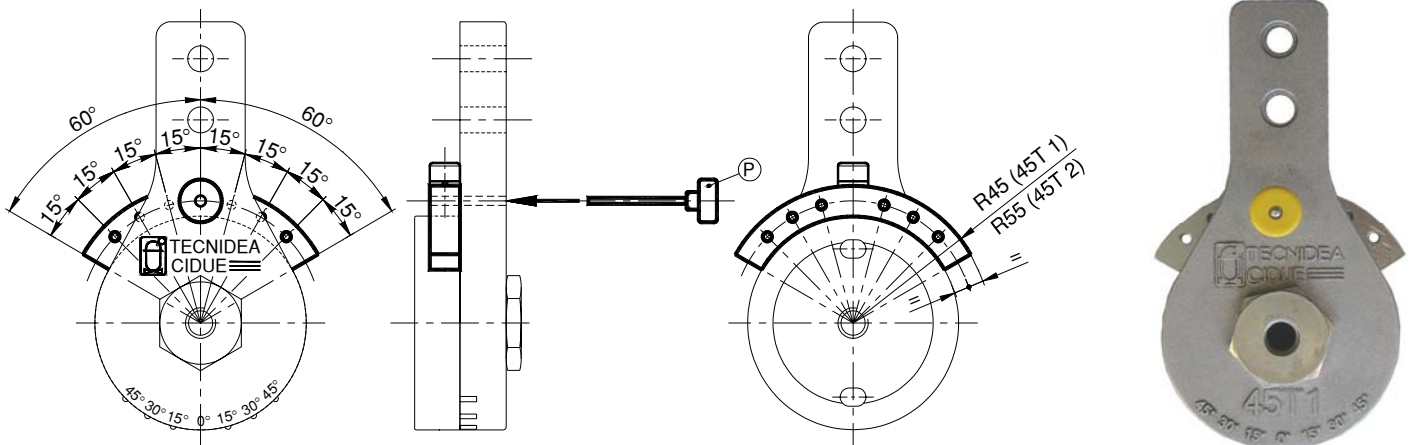

MATERIALI Acciaio.

TRATTAMENTI Zincatura elettrolitica.

IMPIEGO L'accessorio **PF** permette di precaricare l'elemento elastico mediante una spina P con settori multipli di 15° fino ad un massimo di 60°. Una volta che il tenditore è installato sulla trasmissione rimuovere la spina P.

Per ordine: Tipo **PF1** Cod. n° **AS011215**

Tipo **PF2** Cod. n° **AS011216**

MATERIALS Steel.

TREATMENTS Electrolytic zinc plated.

DUTY The **PF** accessory allows to preload the elastic element through a P pin with multiple sectors of 15° up to a maximum of 60°. Once the tightener is installed on the transmission remove the P pin.

In order: Type **PF1** Cod. n° **AS011215**

Type **PF2** Cod. n° **AS011216**

Sistema di precarica con vite di reazione – **PB** / *Preloading system with reaction screw* – **PB**

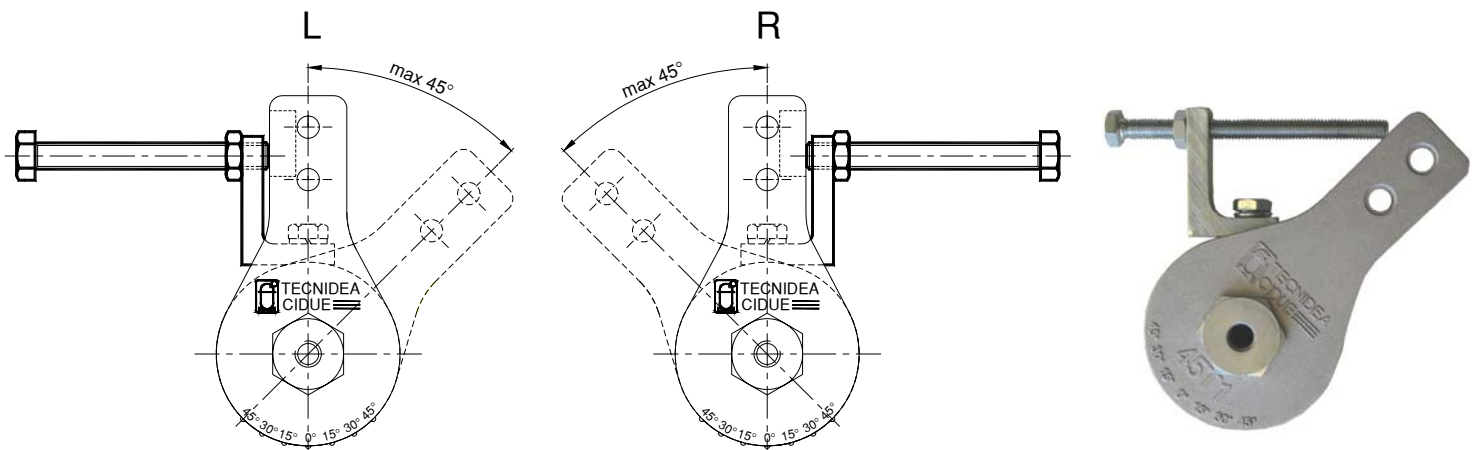

MATERIALI Acciaio.

TRATTAMENTI Zincatura elettrolitica.

IMPIEGO Il sistema di precarica **PB** permette di precaricare l'elemento elastico tramite un braccio di reazione esterno. Una volta installato sull'impianto la vite M deve essere rimossa. Questo accessorio, oltre alla funzione di precarica può essere utilizzato anche come blocco alla rotazione ad un angolo desiderato. La modalità costruttiva dell'accessorio può influire sull'ingombro nel posizionamento del kit. Vi suggeriamo di contattare il nostro ufficio tecnico per la determinazione del montaggio dell'elemento elastico con l'eventuale kit.

Per ordine: Tipo **PB1** Cod. n° **AS011220** (indicare esecuzione L o R)

Tipo **PB2** Cod. n° **AS011222** (indicare esecuzione L o R)

MATERIALS Steel

TREATMENTS Electrolytic zinc plated.

DUTY The preloading system **PB** allows to preload the elastic element through tramite an external reaction arm. Once installed on the system, the screw M must be removed. This accessory, in addition to its preloading function can be used also as block to the rotation wanted. The construction way of the accessory can influence the obstruction in the positioning of the kit. We suggest to contact our technical office for the determination of the assembly of the elastic element with the possible kit.

In order: Type **PB1** Cod. n° **AS011220** (indicate implementation L or R)

Type **PB2** Cod. n° **AS011222** (indicate implementation L or R)

Pattino in polietilene – Tipo: **OVA** / *Polyethylene sliding block – Type: OVA*

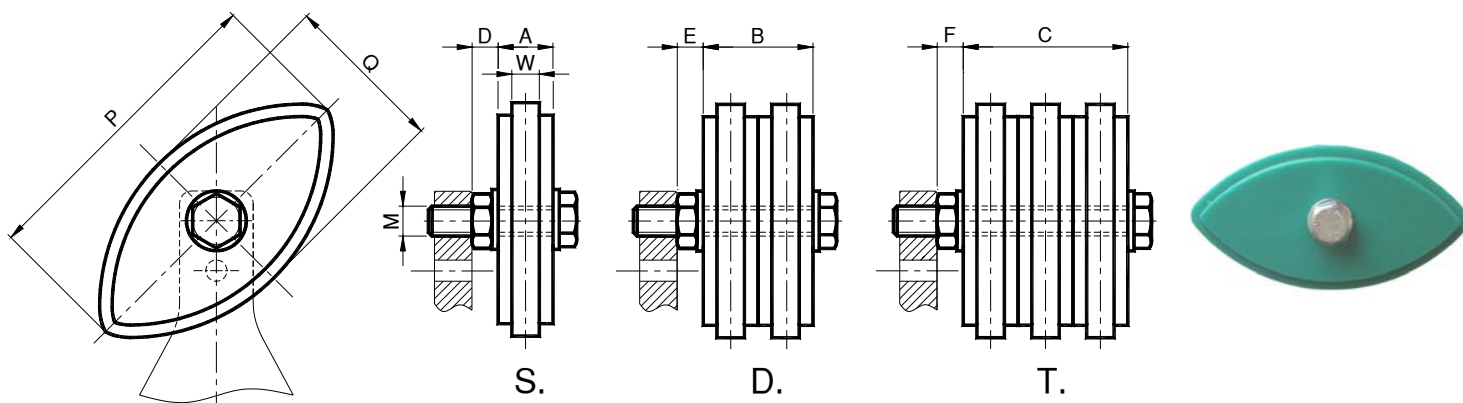

MATERIALI Pattino in polietilene ad alta densità molecolare. Viti in acciaio zincato.

IMPIEGO Profilo semicircolare adatto per medi e grandi interassi.

Velocità di lavoro ≤20 m/min.

Temperatura di lavoro del pattino ≤70°C.

MATERIALS Sliding block made of high molecular density polyethylene. Zinc plated bolts.

USE Semi-circular profile suitable for medium and large interaxis.

Operating speed ≤20 m/min.

Operating sliding block temperature ≤70°C.

Tipo Type	S Cod. N°	D Cod. N°	T Cod. N°	Catena Chain	A	B	C	D	E	F	M	P	Q	W	Peso Weight in Kg		
															S.	D.	T.
OVA 10-1	AR071530	AR071540		3/8"x7/32"	10.2	20.4		6.5	6.5		M8	75	40	5	0.09	0.10	
OVA 20-1			AR071550	3/8"x7/32"			30.6			8	M10	75	40	5			0.13
OVA 30-2	AR071533	AR071542	AR071552	1/2"x5/16"	13.9	27.8	41.7	8	8	8	M10	96	50	7	0.10	0.10	0.14
OVA 30-3	AR071535	AR071544		5/8"x 3/8"	16.6	33.2		8	8		M10	126	65	9	0.12	0.12	
OVA 40-3			AR071556				49.8			9.5	M12	126	65	9			0.27
OVA 40-4	AR071538	AR071548	AR071558	3/4"x7/16"	19.5	39.0	58.5	9.5	9.5	9.5	M12	148	74	12	0.15	0.25	0.28

NEWS: Forze in gioco / Forces at work

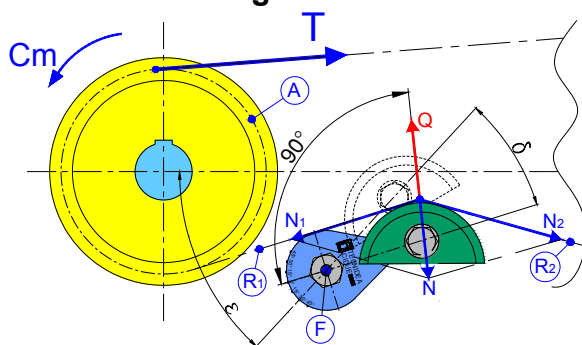

- A = ruota dentata motrice / driving toothed wheel
- T = tensione sul ramo teso / tension on the tensed branch
- C_m = coppia motrice / motor torque
- R₁ = ramo della catena in entrata nel tenditore / section of chain entering the tightener
- R₂ = ramo della catene in uscita dal tenditore / section of chain leaving the tightener
- F = fulcro o punto di rotazione / fulcrum or point of rotation
- Q = forza sprigionata del tenditore / force released by the tightener
- N = forza di reazione della catena / chain reaction force
- N₁ = componente di N sul ramo R₁ / component of N on section R₁
- N₂ = componente di N sul ramo R₂ / component of N on section R₂
- δ = angolo di lavoro del tenditore / tightener positioning angle
- ε = angolo di posizionamento del tenditore / tightener positioning angle

Un tenditore sprigiona una forza Q perpendicolare al braccio di rotazione che per reazione è equilibrata dalla catena con la forza N che si ripartisce con le forze di trazione N₁ e N₂ sui rami in entrata e uscita dal tendicatena rispettivamente R₁ e R₂. Quando si posiziona un tendicatena a rotazione bisogna far attenzione che le forze Q e N siano il più possibile sulla medesima direttrice in modo che non si sviluppino delle componenti tangenziali che vadano a scaricarsi sul fulcro. Il posizionamento del tenditore, quindi, dipende dall'angolo δ, ovvero l'angolo di lavoro dell'elemento elastico, e dall'angolo ε, ovvero l'angolo di posizionamento rispetto alla trasmissione. Il progettista dovrà quindi trovare il giusto rapporto tra questi parametri in funzione della geometria della propria trasmissione.

A tightener releases a force Q perpendicular to the rotation arm which by reaction is balanced by the chain with the force N which is distributed with the traction forces N₁ and N₂ on the sections entering and leaving the chain tightener, respectively R₁ and R₂. When positioning a chain tightener, you must ensure that the forces Q and N are as much as possible on the same line so that there is no formation of tangential components which would be discharged on the fulcrum. The positioning of the tightener therefore depends on the angle δ, that is the working angle of the elastic element, and on the angle ε, that is the positioning angle with respect to the transmission. So the designer must find the right ratio between these parameters according to the geometry of his transmission.

45T Tipo: 45TOVA – 45T Type: 45TOVA

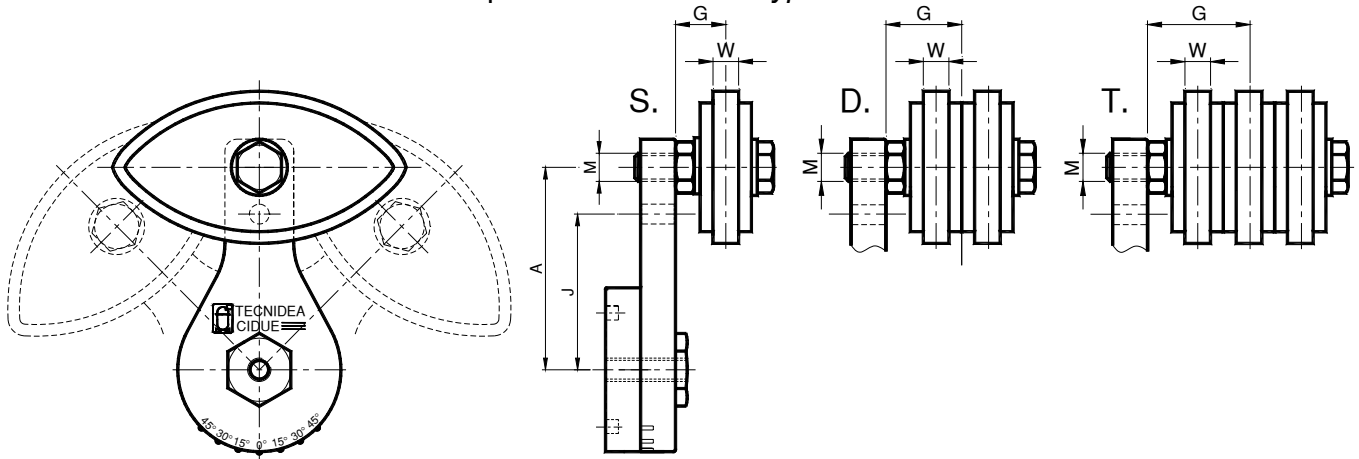

Il tenditore 45TOVA è composto dall'elemento 45T e dal kit per tendicatena OVA. I valori di carico sono riportati a pag 06. Specificare nell'ordine il montaggio del kit sul foro A o J. In mancanza di specifiche richieste sarà fornito posizionato sul foro A.

The tensioner 45TOVA is composed by the element 45T and the chaintensioner kit OVA. The loading values are indicated at page 06. Specify in the order the assembly of the kit on the hole A or J. Failing specific requests, it will be supplied positioned on the hole A.

Catena Chain DIN 8187		45T + OVA	45T		OVA				
			Pag. 06		Pag. 12	G	M	W	
06-B1	3/8" x 7/32"	45T1OVA1S	45T 1-8	AS010900	*OVA 10-1 S	AR071530	6.6	M 8	5
08-B1	1/2" x 5/16"	45T1OVA2S	45T 1-M10	AS010902	OVA 30-2 S	AR071533	14.9	M10	7
10-B1	5/8" x 3/8"	45T1OVA3S	45T 1-M10	AS010902	OVA 30-3 S	AR071535	16.3	M10	9
10-B1	5/8" x 3/8"	45T2OVA3S	45T 2-M10	AS010911	OVA 30-3 S	AR071535	16.3	M10	9
12-B1	3/4" x 7/16"	45T2OVA4S	45T 2-M12	AS010913	OVA 40-4 S	AR071538	19.2	M12	11
06-B2	3/8" x 7/32"	45T1OVA1D	45T 1-8	AS010900	*OVA 10-1 D	AR071540	11.7	M 8	5
08-B2	1/2" x 5/16"	45T1OVA2D	45T 1-M10	AS010902	OVA 30-2 D	AR071542	21.9	M10	7
10-B2	5/8" x 3/8"	45T1OVA3D	45T 1-M10	AS010902	OVA 30-3 D	AR071544	24.6	M10	9
10-B2	5/8" x 3/8"	45T2OVA3D	45T 2-M10	AS010911	OVA 30-3 D	AR071544	24.6	M10	9
12-B2	3/4" x 7/16"	45T2OVA4D	45T 2-M12	AS010913	OVA 40-4 D	AR071548	29.0	M12	11
06-B3	3/8" x 7/32"	45T1OVA1T	45T 1-M10	AS010902	OVA 20-1 T	AR071550	23.3	M10	5
08-B3	1/2" x 5/16"	45T1OVA2T	45T 1-M10	AS010902	OVA 30-2 T	AR071552	28.8	M10	7
10-B3	5/8" x 3/8"	45T1OVA3T	45T 1-M12	AS010904	OVA 40-3 T	AR071556	34.4	M12	9
10-B3	5/8" x 3/8"	45T2OVA3T	45T 2-M12	AS010913	OVA 40-3 T	AR071556	34.4	M12	9
12-B3	3/4" x 7/16"	45T2OVA4T	45T 2-M12	AS010913	OVA 40-4 T	AR071558	38.75	M12	11

*OVA 10-1 S / OVA 10-1 D : il dado va montato dopo il braccio tenditore

* OVA 10-1 S / OVA 10-1 D : the nut must be assembled after the tensioner

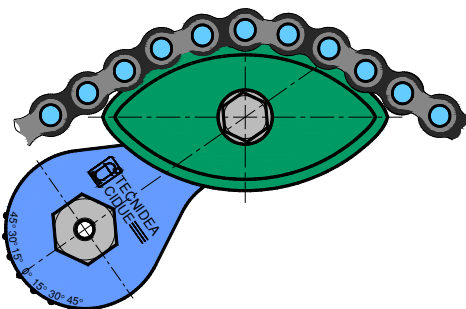

Il pattino OVA consente un'elevata durata di funzionamento in quanto oltre a consentire l'appoggio su più rulli della catena, quindi minor usura, permette di utilizzare un secondo profilo di scorrimento ruotando il pattino.

The OVA sliding block allows a high functional durability as not only allows the support on several chain rollers, which means less wear, but also allows the use of a second sliding profile when rotating the sliding block.

Pattino in polietilene – Tipo: OVR / Polyethylene sliding block – Type: OVR

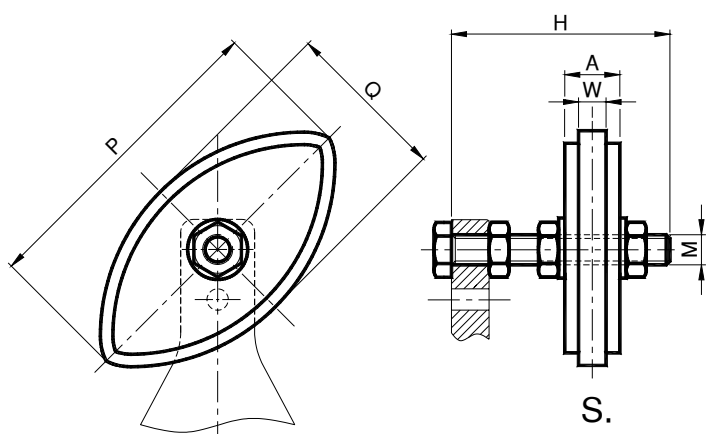

MATERIALI Pattino in polietilene ad alta densità molecolare. Viti in acciaio zincato.
IMPIEGO Profilo semicircolare adatto per medi e grandi interassi.
 Velocità di lavoro ≤20 m/min.
 Temperatura di lavoro del pattino ≤70°C.

MATERIALS Sliding block made of high molecular density polyethylene. Zinc plated bolts.
USE Semi-circular profile suitable for medium and large interaxis.
 Operating speed ≤20 m/min.
 Operating sliding block temperature ≤70°C.

Tipo Type	S Cod. N°	Catena Chain	A	H	M	P	Q	W	Peso Weight in Kg
OVR 10-1	RE011030	3/8" x 7/32"	10.2	45	M8	75	40	5	0.09
OVR 30-2	RE011032	1/2" x 5/16"	13.9	55	M10	96	50	7	0.10
OVR 30-3	RE011034	5/8" x 3/8"	16.6	55	M10	126	65	9	0.12
OVR 40-4	RE011038	3/4" x 7/16"	19.5	80	M12	148	74	11	0.20

NEWS: Nozioni storiche sulle catene / Roller chain historical mentions

Il concetto di trasmissione a catena inizia ad essere sviluppato all'epoca di Leonardo Da Vinci (1453-1519).

Leonardo ne disegna le prime bozze nel contesto dei suoi studi sui cinematismi e meccanismi svolti tra il 1478 ed il 1518.

Queste bozze ed i relativi appunti fanno parte, oggi, del codice Atlantico, una raccolta di 12 volumi che contiene una parte degli studi del Da Vinci di matematica, geometria, astronomia, botanica, zoologia ed arti militari.

Il nome di codice Atlantico deriva dai fogli adoperati in questa raccolta che sono di grande formato, quali, per l'appunto, quelli degli Atlanti geografici.

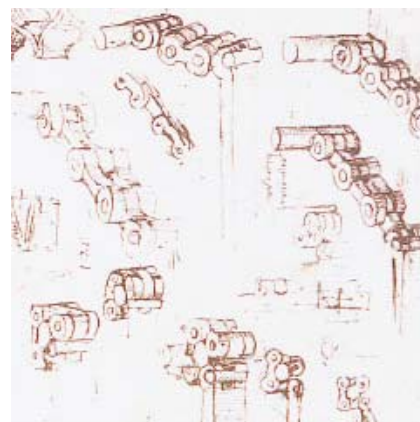

The concept of chain transmission starts to be developed at the time of Leonardo Da Vinci (1453-1519). Leonardo draws some drafts during his studies about kinematic motions and mechanisms between 1478 and 1518. These drafts and its related notes belong, today, to the Atlantic Code, a collection of 12 volumes that contains a part of Da Vinci's studies about math, geometry, astronomy, botany, zoology and military arts. The name "Atlantic Code" comes from papers used in that collection that have big dimensions like papers in the geographic Atlas.

Catena a rulli semplice

E' la più diffusa tra le catene in acciaio grazie alle sue elevate caratteristiche di resistenza all'usura e alla fatica. Lo schema e l'immagine che seguono evidenziano la struttura della catena a rulli:

Simple roller chain

Thanks to its high resistance features against wear and fatigue, the simple roller chain is the most widespread between the steel chains. The following model and image highlighted the structure of roller chain:

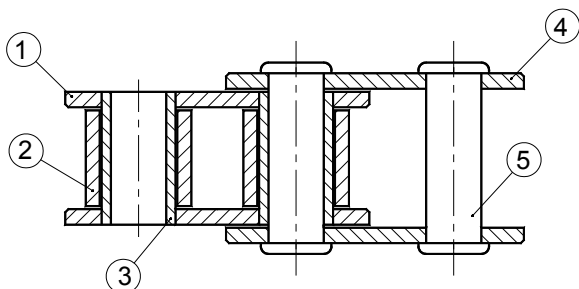

- 1= piastrine interne / internal plates
- 2= rullo / roller
- 3= bussola / bush
- 4= piastrina esterna / external plates
- 5= perno / pin

45T Tipo: 45TOVR – 45T Type: 45TOVR

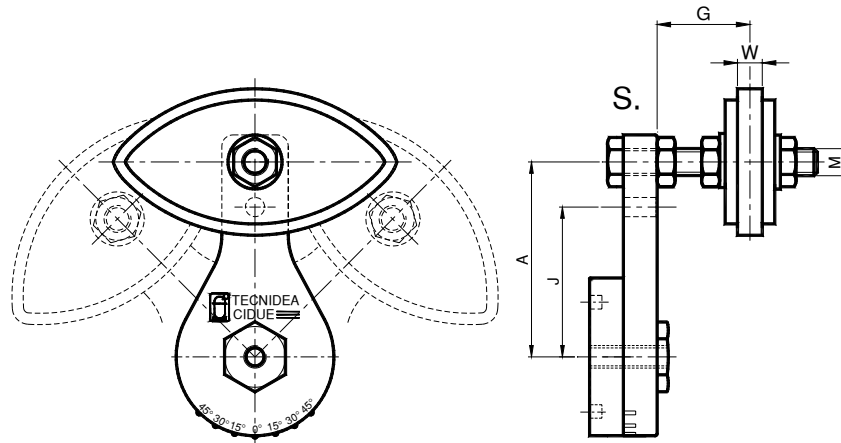

Il tenditore 45TOVR è composto dall'elemento 45T e dal kit per tendicatena OVR. I valori di carico sono riportati a pag 06. Specificare nell'ordine il montaggio del kit sul foro A o J. In mancanza di specifiche richieste sarà fornito posizionato sul foro A.

The tensioner 45TOVR is composed by the element 45T and the chaintensioner kit OVR. The loading values are indicated at page 06. Specify in the order the assembly of the kit on the hole A or J. Failing specific requests, it will be supplied positioned on the hole A.

Catena Chain DIN 8187		45T + OVR	45T		OVR				
			 Pag. 06		 Pag. 14				
					G	M	W		
06-B1	3/8" x 7/32"	45T1OVR1S	45T 1-8	AS010900	OVR 10-1 S	RE011030	5	M8	5
08-B1	1/2" x 5/16"	45T1OVR2S	45T 1-10	AS010901	OVR 30-2 S	RE011032	7	M10	7
10-B1	5/8" x 3/8"	45T1OVR3S	45T 1-10	AS010901	OVR 30-3 S	RE011034	9	M10	9
10-B1	3/4" x 7/16"	45T2OVR3S	45T 2-10	AS010910	*OVR 30-3 S	RE011034	9	M10	9
12-B1	1" x 17.02	45T2OVR4S	45T 2-12	AS010912	OVR 40-4 S	RE011038	11	M12	11

*45T2OVR3S: per il montaggio richiedere scheda istruzioni.

*45T2OVR3S: for the assembly require the instructions sheet.

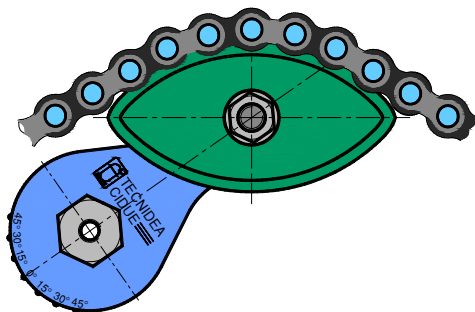

Il pattino OVR consente un'elevata durata di funzionamento in quanto oltre a consentire l'appoggio su più rulli della catena, quindi minor usura, permette di utilizzare un secondo profilo di scorrimento ruotando il pattino.

The OVR sliding block allows an high functional durability as not only allows the support on several chain rollers, which means less wear, but also allows the use of a second sliding profile when rotating the sliding block.

Pattino in polietilene – Tipo: **VB** / Polyethylene sliding block – Type: **VB**

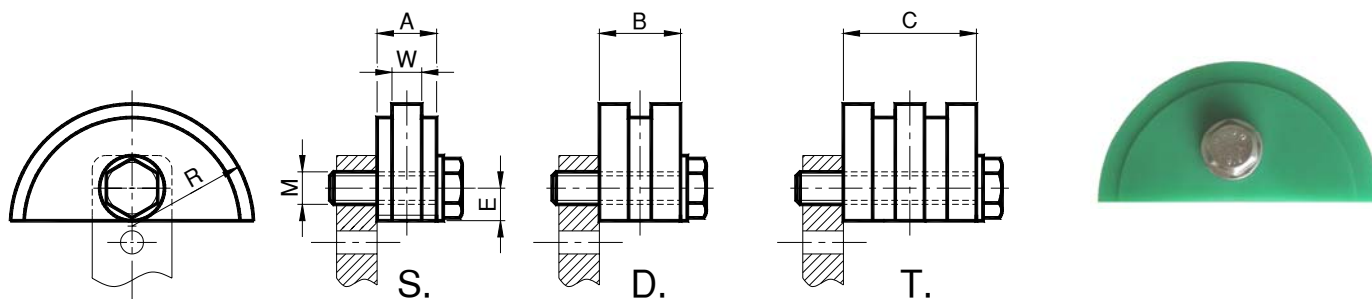

MATERIALI Pattino in polietilene ad alta densità molecolare. Viti in acciaio zincato.
IMPIEGO Profilo semicircolare adatto per piccoli interassi e montaggi vicini al pignone.
 Velocità di lavoro ≤ 20 m/min.
 Temperatura di lavoro del pattino $\leq 70^\circ\text{C}$.

MATERIALS Sliding block made of high molecular density polyethylene. Zinc plated bolts.
USE Semi-circular profile suitable for reduced interaxis and installation close to the pinion.
 Operating speed ≤ 20 m/min.
 Operating temperature $\leq 70^\circ\text{C}$.

Tipo Type	S Cod. N°	D Cod. N°	T Cod. N°	Catena Chain	A	B	C	E	M	R	W	Peso Weight in Kg		
												S.	D.	T.
VB 10-0	AR070640	AR070665		8mm	10	12		10	M10	35	2.5	0.07	0.08	
VB 10-1	AR070641	AR070667		3/8" x 7/32"	10	18		10	M10	35	5	0.07	0.08	
VB 20-1			AR070692	3/8" x 7/32"			25	10	M10	35	5			0.11
VB 30-2	AR070643	AR070669	AR070694	1/2" x 5/16"	14	20.5	34	10	M10	35	7	0.08	0.09	0.12
VB 30-3	AR070646	AR070672		5/8" x 3/8"	16.5	25		12	M10	45	9	0.10	0.11	
VB 40-3			AR070696	5/8" x 3/8"			42	12	M12	45	9			0.22
VB 40-4	AR070649	AR070675	AR070698	3/4" x 7/16"	17.5	30	49	12	M12	45	11	0.13	0.15	0.23
VB 40-5	AR070651	AR070677		1" x 17.02	18	47		20	M12	55	16	0.18	0.26	0.38
VB 50-6	AR070653			1"1/4 x 3/4"	20			20	M16	55	18	0.32	0.50	
VB 50-7	AR070655			1"1/2 x 1"	24			20	M16	55	24	0.33		

Pattini per catene di diverso passo possono essere forniti su richiesta.

Sliding blocks for chains of different pitches can be provided on request.

Esempio di applicazione / Application Example

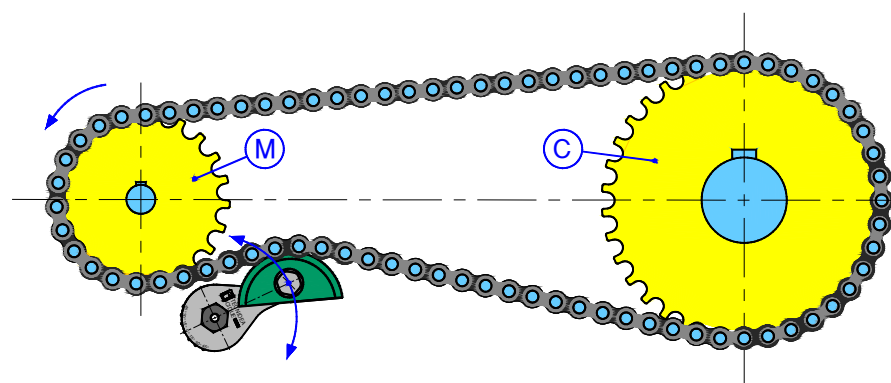

M: Ruota dentata motrice
Driving toothed wheel
C: Ruota dentata condotta
Driven toothed wheel

Il tenditore va montato sul ramo lento della trasmissione con montaggio il più vicino possibile al pignone motore.

The tensioner must be positioned on the loose section of the transmission near to the motor pinion.

45T Tipo: 45TVB – 45T Type: 45TVB

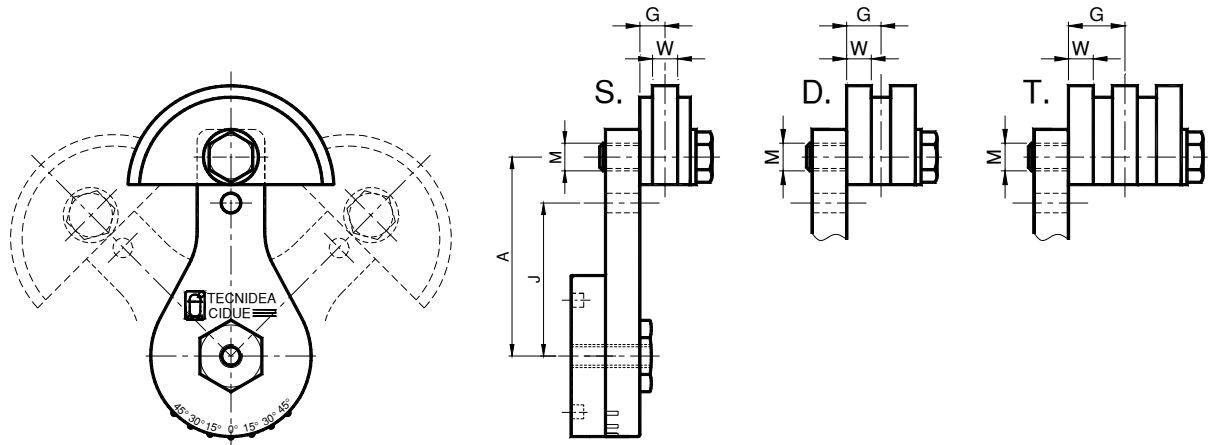

Il tenditore 45TVB è composto dall'elemento 45T e dal kit per tendicatena VB. I valori di carico sono riportati a pag 06. Specificare nell'ordine il montaggio del kit sul foro A o J. In mancanza di specifiche richieste sarà fornito posizionato sul foro A.

The tensioner 45TVB is composed by the element 45T and the chaintensioner kit VB. The loading values are indicated at page 06. Specify in the order the assembly of the kit on the hole A or J. Failing specific requests, it will supplied you positioned on the hole A.

Catena Chain DIN 8187		45T + VB	45T		VB					
			 Pag. 06				G	M	W	
05-B1	8mm	45T1VB0S	45T 1-M10	AS010901	VB 10-0	S	AR070640	5.1	M10	2.5
06-B1	3/8" x 7/32"	45T1VB1S	45T 1-M10	AS010901	VB 10-1	S	AR070641	5.1	M10	5
08-B1	1/2" x 5/16"	45T1VB2S	45T 1-M10	AS010901	VB 30-2	S	AR070643	7.0	M10	7
10-B1	5/8" x 3/8"	45T1VB3S	45T 1-M10	AS010901	VB 30-3	S	AR070646	8.3	M10	9
10-B1	5/8" x 3/8"	45T2VB3S	45T 2-M10	AS010911	VB 30-3	S	AR070646	8.3	M10	9
12-B1	3/4" x 7/16"	45T2VB4S	45T 2-M12	AS010913	VB 40-4	S	AR070649	8.8	M12	11
16-B1	1" x 17.02	45T2VB5S	45T 2-M12	AS010913	VB 40-5	S	AR070651	9.0	M12	16
20-B1	1 1/4" x 3/4"	45T2VB6S	45T 2-M16	AS010916	VB 50-6	S	AR070653	10.0	M16	18
24-B1	1 1/2" x 1"	45T2VB7S	45T 2-M16	AS010916	VB 50-7	S	AR070655	12.0	M16	24
05-B2	8mm	45T1VB0D	45T 1-M10	AS010902	VB 10-0	D	AR070665	6.0	M10	2.5
06-B2	3/8" x 7/32"	45T1VB1D	45T 1-M10	AS010902	VB 10-1	D	AR070667	9.0	M10	5
08-B2	1/2" x 5/16"	45T1VB2D	45T 1-M10	AS010902	VB 30-2	D	AR070669	10.2	M10	7
10-B2	5/8" x 3/8"	45T1VB3D	45T 1-M10	AS010902	VB 30-3	D	AR070672	12.8	M10	9
10-B2	5/8" x 3/8"	45T2VB3D	45T 2-M10	AS010911	VB 30-3	D	AR070672	12.8	M10	9
12-B2	3/4" x 7/16"	45T2VB4D	45T 2-M12	AS010913	VB 40-4	D	AR070675	15.2	M12	11
16-B2	1" x 17.02	45T2VB5D	45T 2-M12	AS010913	VB 40-5	D	AR070677	23.8	M12	16
06-B3	3/8" x 7/32"	45T1VB1T	45T 1-M10	AS010902	VB 20-1	T	AR070692	12.7	M10	5
08-B3	1/2" x 5/16"	45T1VB2T	45T 1-M10	AS010902	VB 30-2	T	AR070694	17.4	M10	7
10-B3	5/8" x 3/8"	45T1VB3T	45T 1-M12	AS010904	VB 40-3	T	AR070696	21.1	M12	9
10-B3	5/8" x 3/8"	45T2VB3T	45T 2-M12	AS010913	VB 40-3	T	AR070696	21.1	M12	9
12-B3	3/4" x 7/16"	45T2VB4T	45T 2-M12	AS010913	VB 40-4	T	AR070698	25.0	M12	11

Pattini per catene di diverso passo possono essere forniti su richiesta.

Sliding blocks for chains of different pitches can be provided on request.

Pattino in polietilene – Tipo: **VR** / Polyethylene sliding block – Type: **VR**

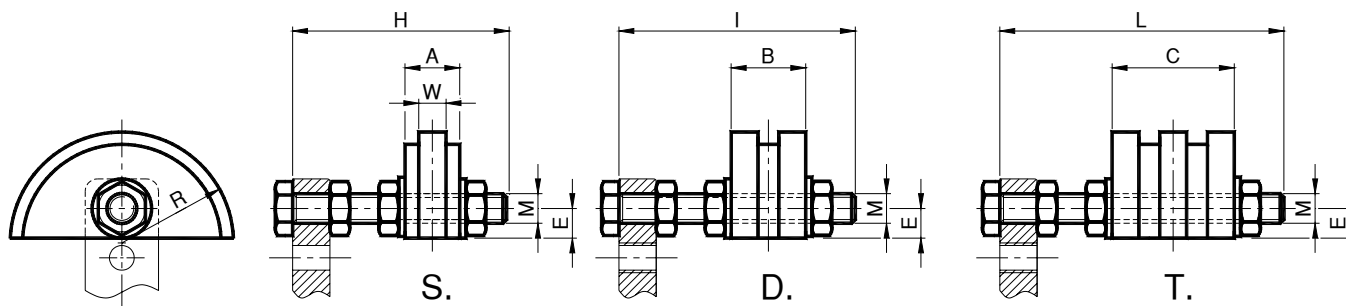

MATERIALI Pattino in polietilene ad alta densità molecolare. Viti in acciaio zincato.
IMPIEGO Profilo semicircolare adatto per piccoli interassi e montaggi vicini al pignone.
 Velocità di lavoro ≤20 m/min.
 Temperatura di lavoro del pattino ≤70°C.

MATERIALS Sliding block made of high molecular density polyethylene. Zinc plated bolts.
USE Semi-circular profile suitable for reduced interaxis and installation close to the pinion.
 Operating speed ≤20 m/min.
 Operating temperature ≤70°C.



Tipo Type	S Cod. N°	D Cod. N°	T Cod. N°	Catena Chain	A	B	C	E	H	I	L	M	R	W	Peso Weight in Kg		
															S.	D.	T.
VR10-0	RE011110	RE011150		8mm	10	12		10	45	45		M8	35	2.5	0.07	0.08	
VR10-1	RE011111	*RE011152		3/8" x 7/32"	10	18		10	45	45		M8	35	5	0.07	0.08	
VR20-1			RE011191	3/8" x 7/32"			25	10			60	M10	35	5			0.11
VR30-2	RE011114	RE011156	RE011194	1/2" x 5/16"	14	20.5	34	10	55	60	70	M10	35	7	0.08	0.09	0.12
VR30-3	RE011117	RE011160		5/8" x 3/8"	16.5	25		12	55	70		M10	45	9	0.10	0.11	
VR40-3			RE011199	5/8" x 3/8"			42	12			100	M12	45	9			0.22
VR40-4	RE011121	RE011164	RE011202	3/4" x 7/16"	17.5	30	49	12	80	80	100	M12	45	11	0.13	0.15	0.23
VR40-5	RE011124	RE011167		1" x 17.02	18	47	79.5	20	80	90		M12	55	16	0.18	0.26	
VR50-6	RE011128			1" 1/4 x 3/4"	20	54	91	20	100			M16	55	18	0.32		
VR50-7	RE011134			1" 1/2 x 1"	24	72	120	20	100			M16	55	24	0.33		

* VR 10-1 D: fornito con due dadi

* VR 10-1 D: supplied with two nuts

Pattini per catene di diverso passo possono essere forniti su richiesta.

Sliding blocks for chains of different pitches can be provided on request.

NEWS: Classificazione tenditori / Tensioner classification

Gli articoli tendicatena e tendicinghia possono essere così suddivisi:

The chain tighteners and belt tighteners articles can be shared out as follows:

AUTOMATICI /AUTOMATIC		MANUALI / MANUAL
ASSIALI / AXIAL	ROTATIONAL	MIX
TEN BLOC	ARCO	PTC
TEN JOY	CRESA	TEN BLOC only type TF
ARIA	CIAO	ASSO only type AH
OLIO	NIC	
ASSO	45T	
BLU		

45T Tipo: 45TVR – 45T Type: 45TVR

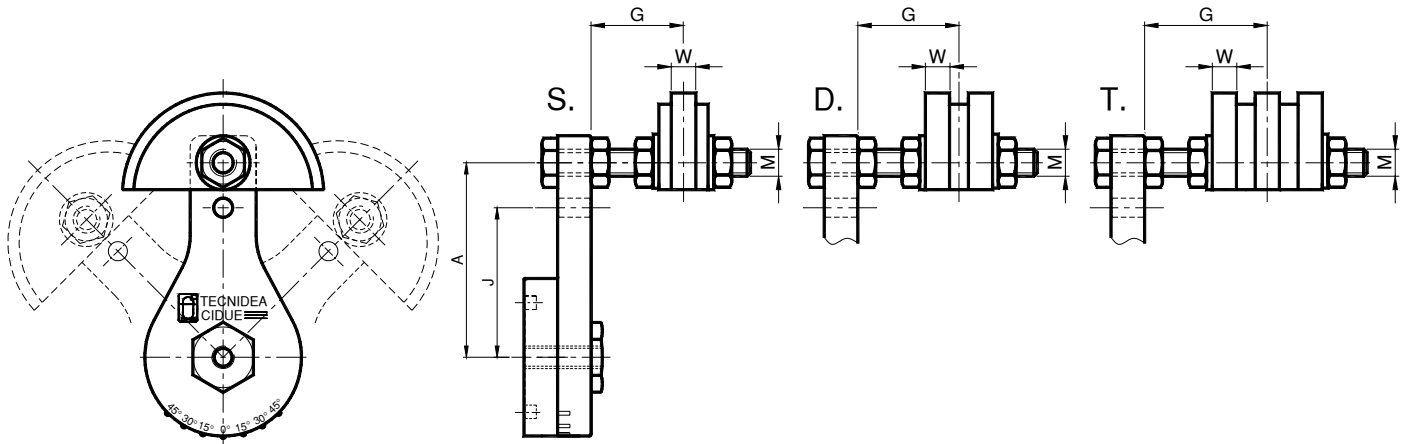

Il tenditore 45TVR è composto dall'elemento 45T e dal kit per tendicatena VR. I valori di carico sono riportati a pag 06. Specificare nell'ordine il montaggio del kit sul foro A o J. In mancanza di specifiche richieste sarà fornito posizionato sul foro A.

The tensioner 45TVR is composed by the element 45T and the chaintensioner kit VR. The loading values are indicated at page 06. Specify in the order the assembly of the kit on the hole A or J. Failing specific requests, it will be supplied positioned on the hole A.

Catena Chain DIN 8187		45T + VR	45T		VR				
			 Pag. 06		 Pag. 18				
						T	M	W	
05-B1	8mm	45T1VR0S	45T 1-8	AS010900	VR 10-0 S	RE011110	16.5-18.5	M8	2.5
06-B1	3/8" x 7/32"	45T1VR1S	45T 1-8	AS010900	VR 10-1 S	RE011111	16.5-18.5	M8	5
08-B1	1/2" x 5/16"	45T1VR2S	45T 1-10	AS010901	VR 30-2 S	RE011114	21.0-25.0	M10	7
10-B1	5/8" x 3/8"	45T1VR3S	45T 1-10	AS010901	VR 30-3 S	RE011117	22.3-23.7	M10	9
10-B1	5/8" x 3/8"	45T2VR3S	45T 2-10	AS010910	VR 30-3 S	RE011117	22.3	M10	9
12-B1	3/4" x 7/16"	45T2VR4S	45T 2-12	AS010912	VR 40-4 S	RE011121	25.2-43.7	M12	11
16-B1	1" x 17.02	45T2VR5S	45T 2-12	AS010912	VR 40-5 S	RE011124	25.5-43.5	M12	16
20-B1	1 1/4" x 3/4"	45T2VR6S	45T 2-16	AS010915	VR 50-6 S	RE011128	31.0-60.0	M16	18
24-B1	1 1/2" x 1"	45T2VR7S	45T 2-16	AS010915	VR 50-7 S	RE011134	33.0-58.0	M16	24
05-B2	8mm	45T1VR0D	45T 1-8	AS010900	VR 10-0 D	RE011150	17.5-19.2	M8	2.5
06-B2	3/8" x 7/32"	45T1VR1D	45T 1-8	AS010900	VR 10-1 D	RE011152	15.5	M8	5
08-B2	1/2" x 5/16"	45T1VR2D	45T 1-10	AS010901	VR 30-2 D	RE011156	24.2-26.2	M10	7
10-B2	5/8" x 3/8"	45T1VR3D	45T 1-10	AS010901	VR 30-3 D	RE011160	26.8-34.2	M10	9
10-B2	5/8" x 3/8"	45T2VR3D	45T 2-10	AS010910	VR 30-3 D	RE011160	26.8-31.2	M10	9
12-B2	3/4" x 7/16"	45T2VR4D	45T 2-12	AS010912	VR 40-4 D	RE011164	31.7-37.2	M12	11
16-B2	1" x 17.02	45T2VR5D	45T 2-12	AS010912	VR 40-5 D	RE011167	40.0	M12	16
06-B3	3/8" x 7/32"	45T1VR1T	45T 1-10	AS010901	VR 20-1 T	RE011191	26.5	M10	5
08-B3	1/2" x 5/16"	45T1VR2T	45T 1-10	AS010901	VR 30-2 T	RE011194	31.0	M10	7
10-B3	5/8" x 3/8"	45T1VR3T	45T 1-12	AS010903	VR 40-3 T	RE011199	37.6-56.9	M12	9
10-B3	5/8" x 3/8"	45T2VR3T	45T 2-12	AS010912	VR 40-3 T	RE011199	37.6-53.9	M12	9
12-B3	3/4" x 7/16"	45T2VR4T	45T 2-12	AS010914	VR 40-4 T	RE011202	41.5-47.5	M12	11

Pattini per catene di diverso passo possono essere forniti su richiesta.

Sliding blocks for chains of different pitches can be provided on request.

Pignone tendicatena (con cuscinetto) – Tipo: **KB** / Sprocket wheel set (with ball bearing) – Type: **KB**

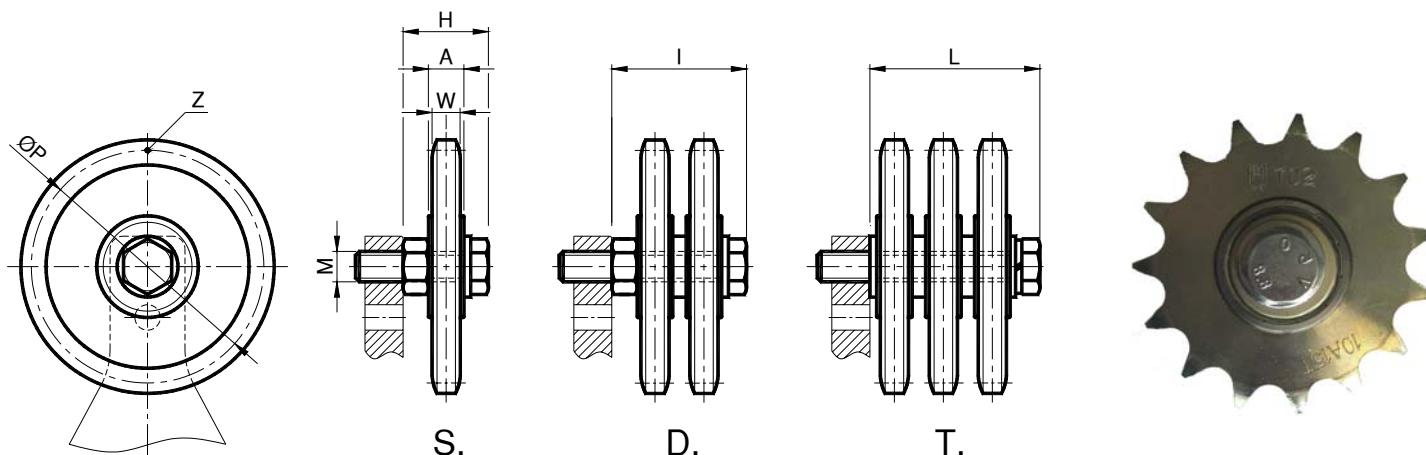

MATERIALI Corona, cuscinetto e vite in acciaio.

TRATTAMENTI Corona e vite in acciaio zincato.

IMPIEGO Il pignone è costituito da una corona in acciaio, montata su cuscinetti unificati.

Velocità di lavoro ≤60 m/min.

Temperatura di lavoro dell'ingranaggio ≤100°C.

MATERIALS Crown, bearing and screw are in steel.

TREATMENTS The crown and the screw are made of zinc plated steel.

USE The sprocket consists of a steel crown, installed on a unified bearing.

Operating speed ≤60 m/min.

Operating temperature ≤100°C.

Tipo Type	S Cod. N°	D Cod. N°	T Cod. N°	Catena Chain	A	H	I	L	M	ØP	W	Z	Peso Weight in Kg		
													S.	D.	T.
KB 30-1	AR071255	AR071279	AR071303	3/8" x 7/32"	9	26	36	47	M10	45.81	5.3	15	0.10	0.22	0.25
KB 30-2	AR071258	AR071282		1/2" x 5/16"	9	26	40		M10	61.09	7.2	15	0.19	0.36	
KB 40-2			AR071305	1/2" x 5/16"	12			58	M12	61.09	7.2	15			0.50
KB 40-3	AR071260	AR071284	AR071307	5/8" x 3/8"	12	35	51	68	M12	76.36	9.1	15	0.35	0.58	0.95
KB 40-4	AR071262	AR071286		3/4" x 7/16"	12	35	55		M12	91.63	11.1	15	0.55	0.98	
KB 50-4			AR071310	3/4" x 7/16"	15	43	63	82	M20	91.63	11.1	15	0.70	1.24	1.55
KB 50-5	AR071265	AR071289		1" x 17.02	15	47	79		M20	106.12	16.2	13	1.12	1.98	
KB 60-5			AR071312	1" x 17.02	15			118	M20	106.12	16.2	13			2.86
KB 60-6	AR071267			1"1/4 x 3/4"	15	58			M20	132.65	18.5	13	2.22		
KB 60-7	AR071269			1"1/2 x 1"	15	60			M20	135.21	24.1	11	2.25		

Ingranaggi per catene di diverso passo o con numero di denti diversi possono essere forniti su richiesta.

Sprockets for chains of different pitches or with a different number of teeth can be provided on request.

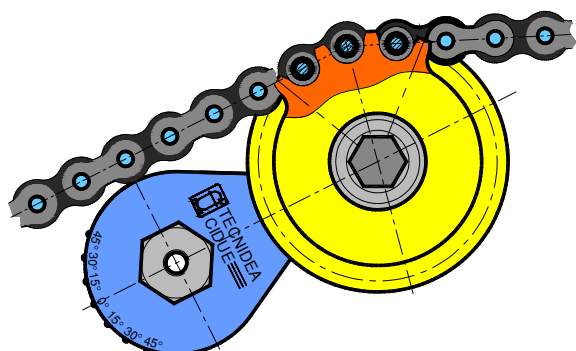

E' consigliabile avere sempre minimo tre rulli di catena a contatto con i denti.

It is recommended to always have a minimum of three chain rollers in contact with the teeth.

45T Tipo: 45TKB – 45T Type: 45TKB

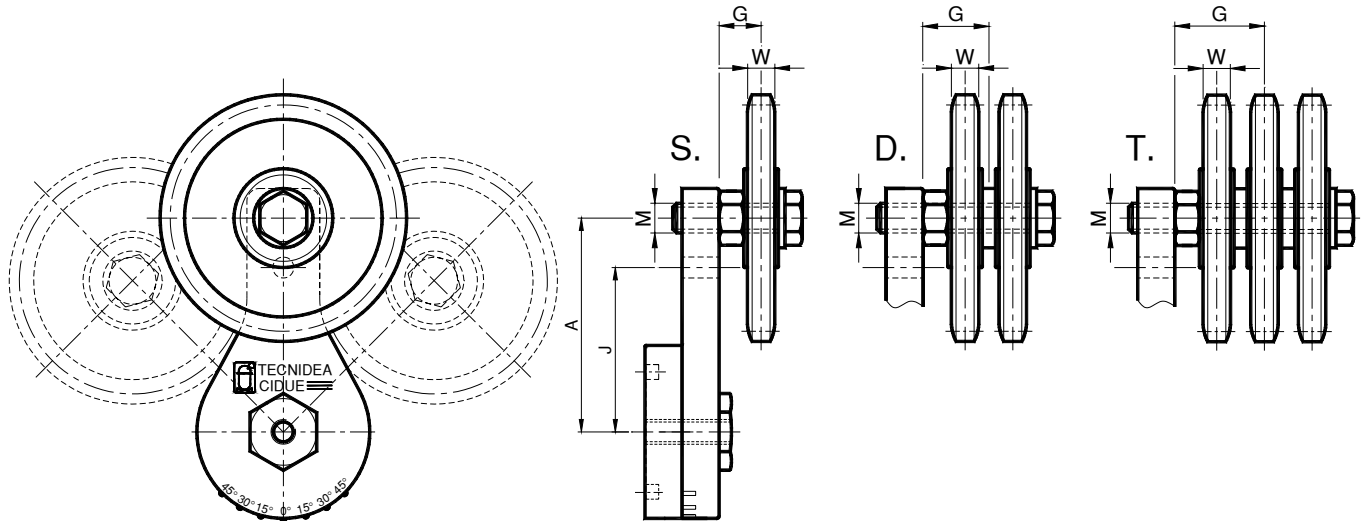

Il tenditore 45TKB è composto dall'elemento 45T e dal kit per tendicatena KB. I valori di carico sono riportati a pag 06. Specificare nell'ordine il montaggio del kit sul foro A o J. In mancanza di specifiche richieste sarà fornito posizionato sul foro A.

The tensioner 45TKB is composed by the element 45T and the chaintensioner kit KB. The loading values are indicated at page 06. Specify in the order the assembly of the kit on the hole A or J. Failing specific requests, it will supplied you positioned on the hole A.

Catena Chain DIN 8187		45T + KB	45T		KB					
						G	M	W	Z	
			Pag. 06		Pag. 20					
06-B1	3/8" x 7/32"	45T1KB1S	45T 1-M10	AS010902	KB 30-1 S	AR071255	12.5	M10	5.3	15
08-B1	1/2" x 5/16"	45T1KB2S	45T 1-M10	AS010902	KB 30-2 S	AR071258	12.5	M10	7.2	15
10-B1	5/8" x 3/8"	45T1KB3S	45T 1-M12	AS010904	KB 40-3 S	AR071260	18.0	M12	9.1	15
10-B1	5/8" x 3/8"	45T2KB3S	45T 2-M12	AS010913	KB 40-3 S	AR071260	18.0	M12	9.1	15
12-B1	3/4" x 7/16"	45T2KB4S	45T 2-M12	AS010913	KB 40-4 S	AR071262	18.5	M12	11.1	15
16-B1	1" x 17.02	45T2KB5S	45T 2-M20	AS010920	KB 50-5 S	AR071265	22.5	M20	16.2	13
20-B1	1"1/4 x 3/4"	45T2KB6S	45T 2-M20	AS010920	KB 60-6 S	AR071267	33.5	M20	18.5	13
24-B1	1"1/2 x 1"	45T2KB7S	45T 2-M20	AS010920	KB 60-7 S	AR071269	33.5	M20	24.1	11
06-B2	3/8" x 7/32"	45T1KB1D	45T 1-M10	AS010902	KB 30-1 D	AR071279	19.0	M10	5.3	15
08-B2	1/2" x 5/16"	45T1KB2D	45T 1-M10	AS010902	KB 30-2 D	AR071282	19.4	M10	7.2	15
10-B2	5/8" x 3/8"	45T1KB3D	45T 1-M12	AS010904	KB 40-3 D	AR071284	26.5	M12	9.1	15
10-B2	5/8" x 3/8"	45T2KB3D	45T 2-M12	AS010904	KB 40-3 D	AR071284	26.5	M12	9.1	15
12-B2	3/4" x 7/16"	45T2KB4D	45T 2-M12	AS010904	KB 40-4 D	AR071286	28.2	M12	11.1	15
16-B2	1" x 17.02	45T2KB5D	45T 2-M20	AS010920	KB 50-5 D	AR071289	38.5	M20	16.2	13
06-B3	3/8" x 7/32"	45T1KB1T	45T 1-M10	AS010902	KB 30-1 T	AR071303	21.5	M10	5.3	15
08-B3	1/2" x 5/16"	45T2KB2T	45T 2-M12	AS010913	KB 40-2 T	AR071305	30.5	M12	7.2	15
10-B3	5/8" x 3/8"	45T2KB3T	45T 2-M12	AS010913	KB 40-3 T	AR071307	35.0	M12	9.1	15
12-B3	3/4" x 7/16"	45T2KB4T	45T 2-M20	AS010920	KB 50-4 T	AR071310	31.5	M20	11.1	15
16-B3	1" x 17.02	45T2KB5T	45T 2-M20	AS010920	KB 60-5 T	AR071312	62.5	M20	16.2	13

Nel caso di impieghi con quota G diversa da quella indicata in tabella consigliamo di consultare il nostro ufficio tecnico. Ingranaggi per catene di diverso passo o con numero di denti diversi possono essere forniti su richiesta.

In case of uses with a different A level than that indicated in the chart, we suggest to consult our technical office. Sprockets for chains of different pitches or with a different number of teeth can be provided on request.

Pignone tendicatena (con cuscinetto) – Tipo: **ZK** / *Sprocket wheel set (with ball bearing)* – Type: **ZK**

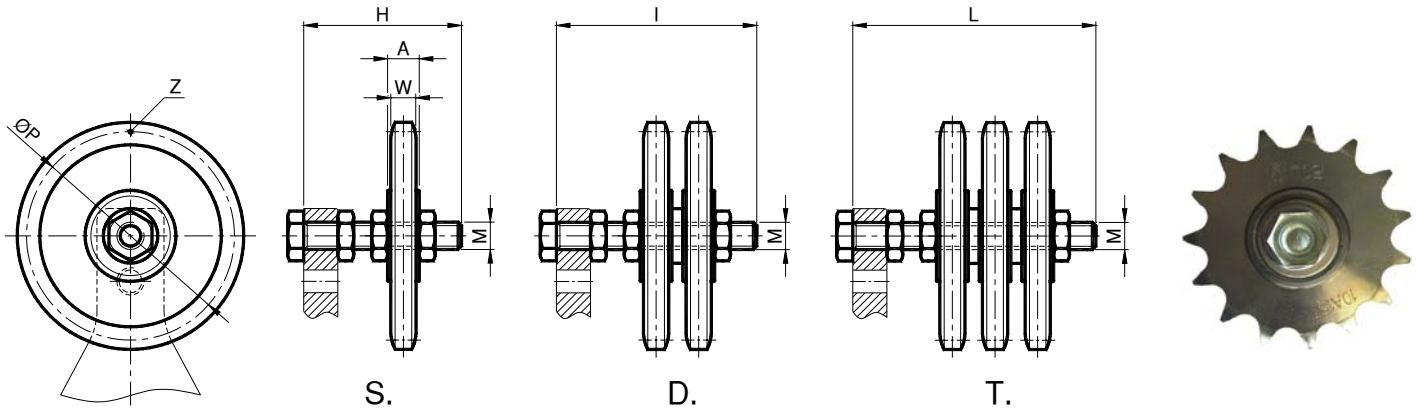

Tipo Type	S Cod. N°	D Cod. N°	T Cod. N°	Catena Chain	A	H	I	L	M	ØP	W	Z	Peso Weight in Kg		
													S.	D.	T.
ZK 30-1	RE011691	RE011728	RE011764	3/8" x 7/32"	9	55	60	70	M10	45.81	5.3	15	0.13	0.23	0.26
ZK 30-2	RE011694	RE011731		1/2" x 5/16"	9	55	60		M10	61.09	7.2	15	0.21	0.37	
ZK 40-2			RE011768	1/2" x 5/16"	12			80	M12	61.09	7.2	15			0.51
ZK 40-3	RE011698	*RE011735	RE011771	5/8" x 3/8"	12	80	80	80	M12	76.36	9.1	15	0.38	0.60	0.96
ZK 40-4	RE011701	RE011738		3/4" x 7/16"	12	80	80		M12	91.63	11.1	15	0.56	1.00	
ZK 50-4			RE011776	3/4" x 7/16"	15			120	M20	91.63	11.1	15			1.60
ZK 50-5	RE011706	RE011743		1" x 17.02	15	100	120		M20	106.12	16.2	13	1.23	2.10	
ZK 60-5			RE011780	1" x 17.02	15			160	M20	106.12	16.2	13			2.92
ZK 60-6	RE011710	RE011747		1"1/4 x 3/4"	15	100	140		M20	132.65	18.5	13	2.28	3.60	
ZK 60-7	RE011714	RE011751		1"1/2 x 1"	15	140	140		M20	135.21	24.1	11	2.33	4.20	

* ZK 40-3 D: fornito con due dadi
* ZK 40-3 D: supplied with two nuts

NEWS: Settori di applicazione / Application Area



Automation movement



Bottling



Packaging

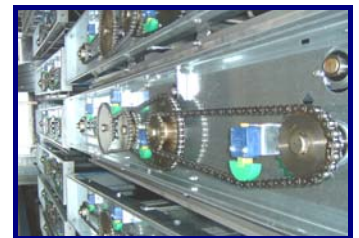

Aviculture



Food



Textile



Steelworks Foundries



Agriculture

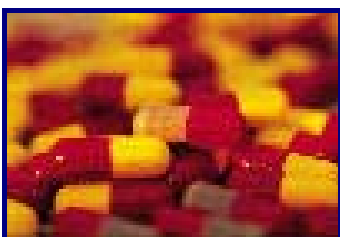

Pharmaceutical



Construction Trade



Recycling

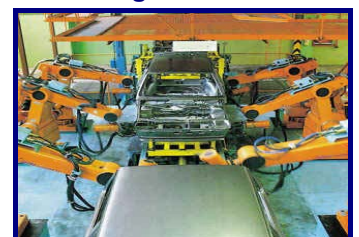

Automotive

45T Tipo: 45TZK – 45T Type: 45TZK

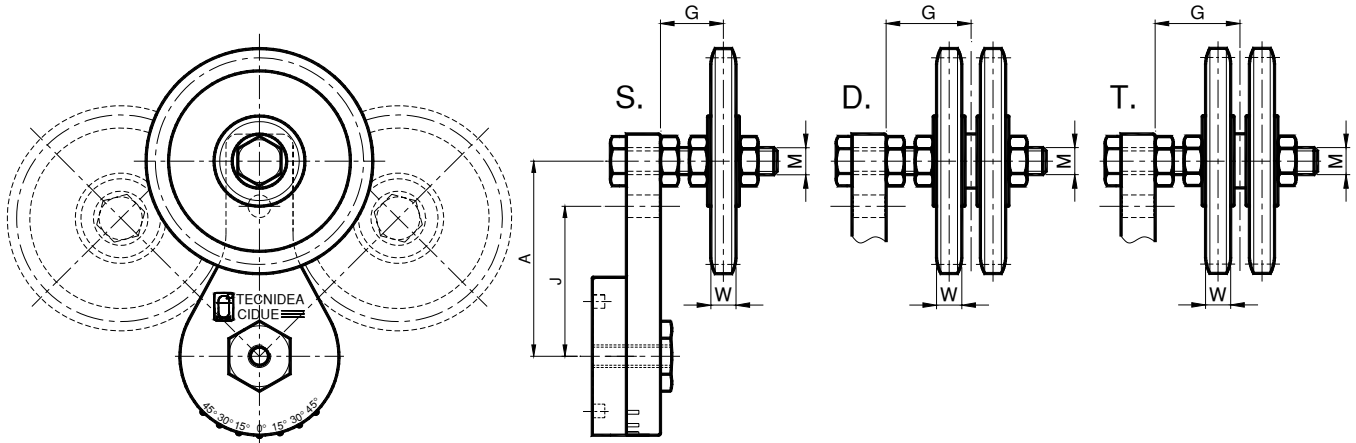

Il tenditore 45TZK è composto dall'elemento 45T e dal kit per tendicatena ZK. I valori di carico sono riportati a pag 06. Specificare nell'ordine il montaggio del kit sul foro A o J. In mancanza di specifiche richieste sarà fornito posizionato sul foro A.

The tensioner 45TZK is composed by the element 45T and the chaintensioner kit ZK. The loading values are indicated at page 06. Specify in the order the assembly of the kit on the hole A or J. Failing specific requests, it will supplied you positioned on the hole A.

Catena Chain DIN 8187		45T + ZK	45T	ZK						
			 Pag. 06							
						G	M	W	Z	
06-B1	3/8" x 7/32"	45T1ZK1S	45T 1-10	AS010901	ZK 30-1 S	RE011691	16.5-29.5	M10	5.3	15
08-B1	1/2" x 5/16"	45T1ZK2S	45T 1-10	AS010901	ZK 30-2 S	RE011694	16.5-29.5	M10	7.2	15
10-B1	5/8" x 3/8"	45T1ZK3S	45T 1-12	AS010903	ZK 40-3 S	RE011698	20.0-52.0	M12	9.1	15
10-B1	5/8" x 3/8"	45T2ZK3S	45T 2-12	AS010912	ZK 40-3 S	RE011698	20.0-49.0	M12	9.1	15
12-B1	3/4" x 7/16"	45T2ZK4S	45T 2-12	AS010912	ZK 40-4 S	RE011701	20.0-49.0	M12	11.1	15
16-B1	1" x 17.02	45T2ZK5S	45T 2-20	AS010919	ZK 50-5 S	RE011706	25.5-65.5	M20	16.2	13
20-B1	1"1/4 x 3/4"	45T2ZK6S	45T 2-20	AS010919	ZK 60-6 S	RE011710	25.5-65.5	M20	18.5	13
24-B1	1"1/2 x 1"	45T2ZK7S	45T 2-20	AS010919	ZK 60-7 S	RE011714	25.5-105.5	M20	24.1	11
06-B2	3/8" x 7/32"	45T1ZK1D	45T 1-10	AS010901	ZK 30-1 D	RE011728	22.0-29.0	M10	5.3	15
08-B2	1/2" x 5/16"	45T1ZK2D	45T 1-10	AS010901	ZK 30-2 D	RE011731	23.4-28.4	M10	7.2	15
10-B2	5/8" x 3/8"	45T1ZK3D	45T 1-12	AS010903	ZK 40-3 D	RE011735	28.5-43.5	M12	9.1	15
10-B2	5/8" x 3/8"	45T2ZK3D	45T 2-12	AS010912	ZK 40-3 D	RE011735	28.5-40.5	M12	9.1	15
12-B2	3/4" x 7/16"	45T2ZK4D	45T 2-12	AS010912	ZK 40-4 D	RE011738	29.7-39.2	M12	11.1	15
16-B2	1" x 17.02	45T2ZK5D	45T 2-20	AS010919	ZK 50-5 D	RE011743	64.0-87.5	M20	16.2	13
20-B2	1"1/4 x 3/4"	45T2ZK6D	45T 2-20	AS010919	ZK 60-6 D	RE011747	43.7-88.7	M20	18.5	13
24-B2	1"1/2 x 1"	45T2ZK7D	45T 2-20	AS010919	ZK 60-7 D	RE011751	50.0-81.0	M20	24.1	11
06-B3	3/8" x 7/32"	45T1ZK1T	45T 1-10	AS010901	ZK 30-1 T	RE011764	25.5-35.5	M10	5.3	15
08-B3	1/2" x 5/16"	45T2ZK2T	45T 2-12	AS010912	ZK 40-2 T	RE011768	34.5	M12	7.2	15
10-B3	5/8" x 3/8"	45T2ZK3T	45T 2-12	AS010912	ZK 40-3 T	RE011771	30.0	M12	9.1	15
12-B3	3/4" x 7/16"	45T2ZK4T	45T 2-20	AS010919	ZK 50-4 T	RE011776	46.5-64.5	M20	11.1	15
16-B3	1" x 17.02	45T2ZK5T	45T 2-20	AS010919	ZK 60-5 T	RE011780	57.5-93.5	M20	16.2	13

Nel caso di impieghi con quota G diversa da quella indicata in tabella consigliamo di consultare il nostro ufficio tecnico. Ingranaggi per catene di diverso passo o con numero di denti diversi possono essere forniti su richiesta.

In case of uses with a different G dimension than that indicated in the chart, we suggest to consult our technical office. Sprockets for chains with different pitches or with a different number of theet can be provided on demand.

Pignone tendicatena (con cuscinetto nazionale) – Tipo: **NB** / Sprocket wheel set (with national bearing) – Type: **NB**
 Pignone tendicatena (con cuscinetto INA) – Tipo: **IB** / Sprocket wheel set (with INA bearing) – Type: **IB**

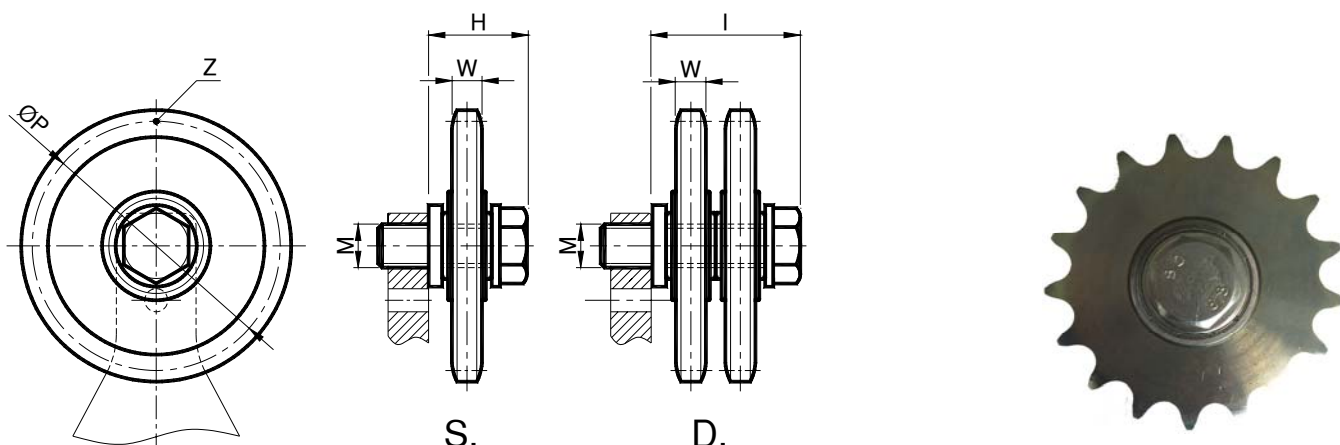

MATERIALI Corona, cuscinetto e vite in acciaio.

TRATTAMENTI Corona e vite in acciaio zincato.

IMPIEGO Il pignone è costituito da una corona in acciaio, montata su cuscinetti nazionali con base maggiorata (tipo NB) o INA (tipo IB).

Velocità di lavoro ≤60 m/min.

Temperatura di lavoro dell'ingranaggio ≤100°C.

MATERIALS Crown, bearing and screw are in steel.

TREATMENTS The crown and the screw are made of zinc plated steel.

USE The sprocket consists of a steel crown, installed on national (type NB) or INA (type IB) enlarged bearings.

Operating speed ≤60 m/min.

Operating temperature ≤100°C.

NB: Pignone tendicatena
(con cuscinetto nazionale)
NB: Sprocket wheel set
(with national bearing)

IB: Pignone tendicatena
(con cuscinetto INA)
IB: Sprocket wheel set
(with INA bearing)

Tipo Type	S Cod. N°	D Cod. N°	Catena Chain	Tipo Type	S Cod. N°	D Cod. N°	H	I	M	ØP	Z	W	Peso Weight in Kg	
													S.	D.
NB 20-1	AR071099	AR071126	3/8" x 7/32"	IB 20-1	AR071177	AR071204	34	50	M16	63.90	21	5.3	0.25	0.40
NB 30-2	AR071102	AR071129	1/2" x 5/16"	IB 30-2	AR071180	AR071207	34	50	M16	73.14	18	7.2	0.35	0.60
NB 40-3	AR071105	AR071132	5/8" x 3/8"	IB 40-3	AR071183	AR071210	39	58	M16	86.39	17	9.1	0.51	0.89
NB 40-4	AR071108	AR071134	3/4" x 7/16"	IB 40-4	AR071186	AR071212	39	58	M16	91.63	15	11.1	0.65	1.15
NB 50-5	AR071112	AR071138	1" x 17.02	IB 50-5	AR071190	AR071216	50	82	M20	98.14	12	16.2	0.98	1.76
NB 60-6	AR071114		1"1/4 x 3/4"	IB 60-6	AR071192	AR071218	58		M20	132.65	13	18.5	2.22	
NB 60-7	AR071116		1"1/2 x 1"	IB 60-7	AR071194	AR071220	60		M20	135.21	11	24.1	2.25	

Ingranaggi per catene di diverso passo o con numero di denti diversi possono essere forniti su richiesta.

Sprockets for chains of different pitches or with a different number of teeth can be provided on request.

45T Tipo: 45TNB – 45T Type: 45TNB

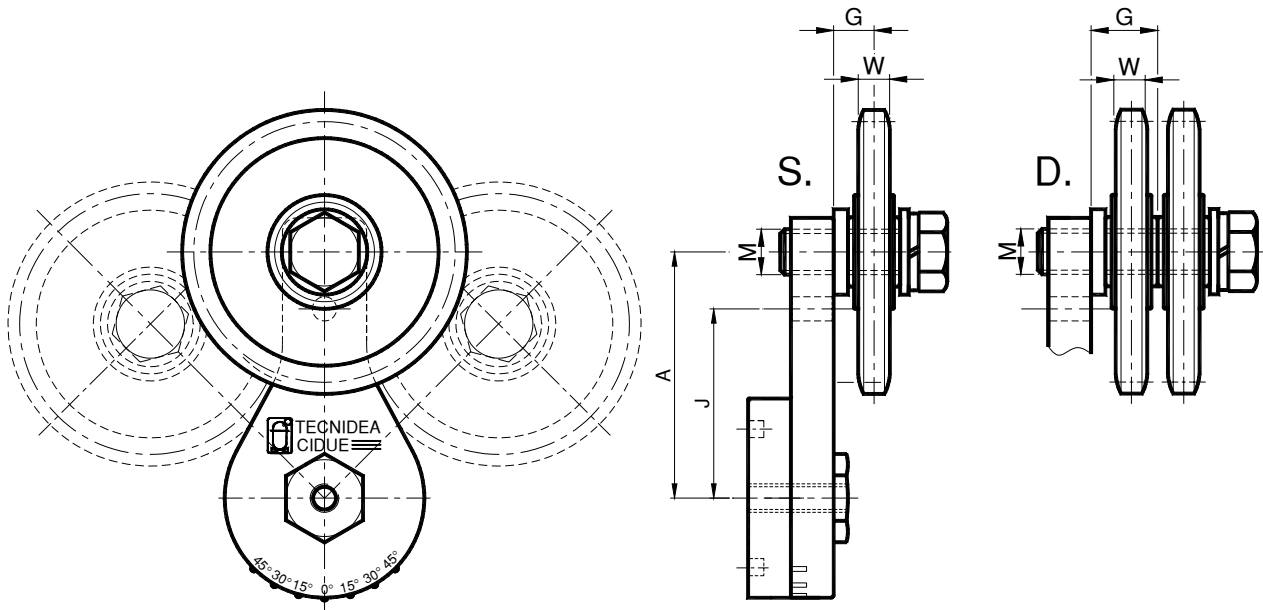

Il tenditore 45TNB è composto dall'elemento 45T e dal kit per tendicatena NB. I valori di carico sono riportati a pag 06. Specificare nell'ordine il montaggio del kit sul foro A o J. In mancanza di specifiche richieste sarà fornito posizionato sul foro A.

The tensioner 45TNB is composed by the element 45T and the chaintensioner kit NB. The loading values are indicated at page 06. Specify in the order the assembly of the kit on the hole A or J. Failing specific requests, it will be supplied positioned on the hole A.

Catena Chain DIN 8187		45T + NB	45T		NB					
			 Pag. 06		 Pag. 24	G	M	W	Z	
06-B1	3/8" x 7/32"	45T1NB1S	45T 1-M16	AS010907	NB 20-1 S	AR071099	12.1	M16	5.3	21
08-B1	1/2" x 5/16"	45T1NB2S	45T 1-M16	AS010907	NB 30-2 S	AR071102	12.1	M16	7.2	18
10-B1	5/8" x 3/8"	45T1NB3S	45T 1-M16	AS010907	NB 40-3 S	AR071104	12.1	M16	9.1	17
10-B1	5/8" x 3/8"	45T2NB3S	45T 2-M16	AS010916	NB 40-3 S	AR071104	12.1	M16	9.1	17
12-B1	3/4" x 7/16"	45T2NB4S	45T 2-M16	AS010916	NB 40-4 S	AR071108	17.1	M16	11.1	15
16-B1	1" x 17.02	45T2NB5S	45T 2-M20	AS010920	NB 50-5 S	AR071112	24.8	M20	16.2	12
20-B1	1"1/4 x 3/4"	45T2NB6S	45T 2-M20	AS010920	NB 60-6 S	AR071114	33.5	M20	18.5	13
24-B1	1"1/2 x 1"	45T2NB7S	45T 2-M20	AS010920	NB 60-7 S	AR071116	33.5	M20	24.1	11
06-B2	3/8" x 7/32"	45T1NB1D	45T 1-M16	AS010907	NB 20-1 D	AR071126	18.3	M16	5.3	21
08-B2	1/2" x 5/16"	45T1NB2D	45T 1-M16	AS010907	NB 30-2 D	AR071129	18.3	M16	7.2	18
10-B2	5/8" x 3/8"	45T1NB3D	45T 1-M16	AS010907	NB 40-3 D	AR071132	26.3	M16	9.1	17
10-B2	5/8" x 3/8"	45T2NB3D	45T 2-M16	AS010916	NB 40-3 D	AR071132	26.3	M16	9.1	17
12-B2	3/4" x 7/16"	45T2NB4D	45T 2-M16	AS010916	NB 40-4 D	AR071134	26.3	M16	11.1	15
16-B2	1" x 17.02	45T2NB5D	45T 2-M20	AS010920	NB 50-5 D	AR071138	40.7	M20	16.2	12

Nel caso di impieghi con quota G diversa da quella indicata in tabella consigliamo di consultare il nostro ufficio tecnico. Ingranaggi per catene di diverso passo o con numero di denti diversi possono essere forniti su richiesta.

In case of uses with a different G level than that indicated in the chart, we suggest to consult our technical office. Sprockets for chains of different pitches or with a different number of teeth can be provided on request.

45T Tipo: 45TIB – 45T Type: 45TIB

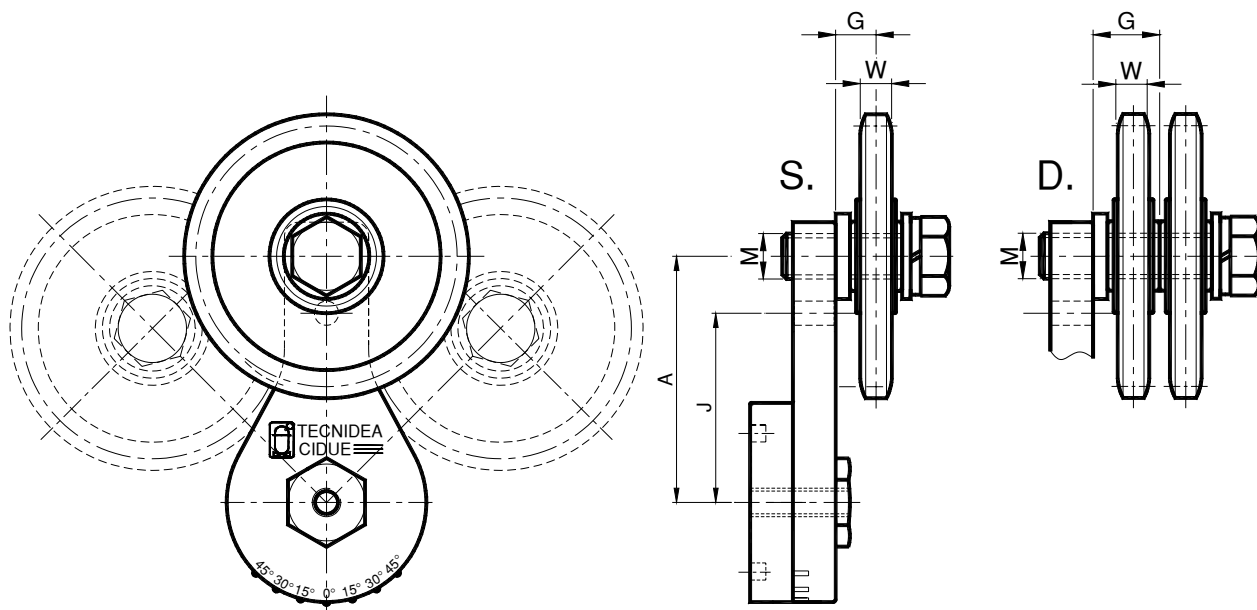

Il tenditore 45TIB è composto dall'elemento 45T e dal kit per tendicatena IB. I valori di carico sono riportati a pag 06. Specificare nell'ordine il montaggio del kit sul foro A o J. In mancanza di specifiche richieste sarà fornito posizionato sul foro A.

The tensioner 45TIB is composed by the element 45T and the chaintensioner kit IB. The loading values are indicated at page 06. Specify in the order the assembly of the kit on the hole A or J. Failing specific requests, it will supplied you positioned on the hole A.

Catena Chain DIN 8187		45T + IB	45T		IB					
			 Pag. 06			G	M	W	Z	
					Pag. 24					
06-B1	3/8" x 7/32"	45T1IB1S	45T 1-M16	AS010907	IB 20-1 S	AR071177	12.1	M16	5.3	21
08-B1	1/2" x 5/16"	45T1IB2S	45T 1-M16	AS010907	IB 30-2 S	AR071180	12.1	M16	7.2	18
10-B1	5/8" x 3/8"	45T1IB3S	45T 1-M16	AS010907	IB 40-3 S	AR071183	12.1	M16	9.1	17
10-B1	5/8" x 3/8"	45T2IB3S	45T 2-M16	AS010916	IB 40-3 S	AR071183	12.1	M16	9.1	17
12-B1	3/4" x 7/16"	45T2IB4S	45T 2-M16	AS010916	IB 40-4 S	AR071186	17.1	M16	11.1	15
16-B1	1" x 17.02	45T2IB5S	45T 2-M20	AS010920	IB 50-5 S	AR071190	24.8	M20	16.2	12
20-B1	1"1/4 x 3/4"	45T2IB6S	45T 2-M20	AS010920	IB 60-6 S	AR071192	33.5	M20	18.5	13
24-B1	1"1/2 x 1"	45T2IB7S	45T 2-M20	AS010920	IB 60-7 S	AR071194	33.5	M20	24.1	11
06-B2	3/8" x 7/32"	45T1IB1D	45T 1-M16	AS010907	IB 20-1 D	AR071204	18.3	M16	5.3	21
08-B2	1/2" x 5/16"	45T1IB2D	45T 1-M16	AS010907	IB 30-2 D	AR071207	18.3	M16	7.2	18
10-B2	5/8" x 3/8"	45T1IB3D	45T 1-M16	AS010907	IB 40-3 D	AR071210	26.3	M16	9.1	17
10-B2	5/8" x 3/8"	45T2IB3D	45T 2-M16	AS010916	IB 40-3 D	AR071210	26.3	M16	9.1	17
12-B2	3/4" x 7/16"	45T2IB4D	45T 2-M16	AS010916	IB 40-4 D	AR071212	26.3	M16	11.1	15
16-B2	1" x 17.02	45T2IB5D	45T 2-M20	AS010920	IB 50-5 D	AR071216	40.7	M20	16.2	12

Nel caso di impieghi con quota G diversa da quella indicata in tabella consigliamo di consultare il nostro ufficio tecnico. Ingranaggi per catene di diverso passo o con numero di denti diversi possono essere forniti su richiesta.

In case of uses with a different G level than that indicated in the chart, we suggest to consult our technical office. Sprockets for chains of different pitches or with a different number of teeth can be provided on request.

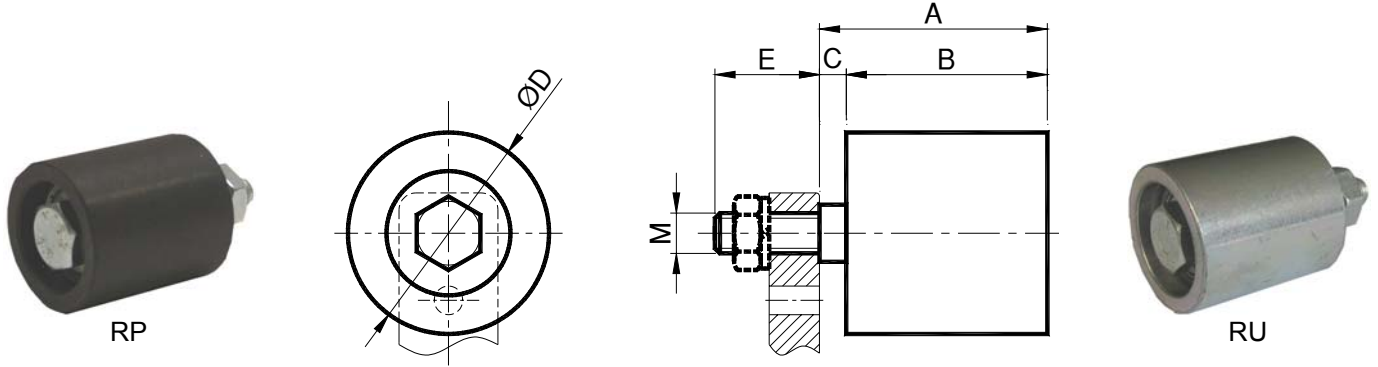
Rullo in poliammide – Tipo: **RP** / Rullo in acciaio zincato – Type: **RU**

MATERIALI Rullo in poliammide PA6+MoS nero, cuscinetti e distanziali in acciaio.

TRATTAMENTI Particolari metallici in acciaio zincato. Rullo tornito 1.6. Cuscinetti lubrificati.

IMPIEGO Rullo per tendicinghia. Temperatura di lavoro $\leq 70^{\circ}\text{C}$.

MATERIALS Roller made of polyamide PA6+MoS black, bearings and spacers made of steel.
TREATMENTS Metallic components made of zinc plated steel. The roller is turned 1.6. Greased bearings.
USE Belt tensioning.
 Operating temperature $\leq 70^{\circ}\text{C}$.

MATERIALI Rullo, cuscinetti e distanziali in acciaio.

TRATTAMENTI Particolari metallici in acciaio zincato. Cuscinetti lubrificati.

IMPIEGO Rullo per tendicinghia. Temperatura di lavoro $\leq 100^{\circ}\text{C}$.

MATERIALS Roller, bearings and spacers made of steel.
TREATMENTS Metallic components made of galvanized steel.
USE Belt tensioning.
 Operating temperature $\leq 100^{\circ}\text{C}$.

Tipo Type	Cod. N°	A	B	C	ØD	E	M	Peso Weight in Kg
RP 1T	RE011091	38	35	3	30	33	M 8	0.08
RP 2/3	RE011092	51	45	6	40	16	M10	0.18
RP 4	RE011094	68	60	8	60	21	M12	0.40
RP 5	RE011096	99	90	9	80	28	M20	1.20
RU 1T	AR070871	38	35	3	30	33	M 8	0.16
RU 2/3	AR070872	51	45	6	40	16	M10	0.37
RU 4	AR070874	68	60	8	60	21	M16	0.85
RU 5	AR070876	99	90	9	80	28	M20	2.09

Campo di lavoro Working field				Campo di lavoro Working field			
Tipo Type	Ø Rullo Roller	Numero di giri max Max rpm	Cuscinetto Bearing	Tipo Type	Ø Rullo Roller	Numero di giri max Max rpm	Cuscinetto Bearing
RP 1T	30	8000	608	RU 1T	30	15000	608
RP 2/3	40	8000	6200	RU 2/3	40	12000	6200
RP 4	60	6000	6304	RU 4	60	9500	6304
RP 5	80	5000	6304	RU 5	80	6500	6306

Il numero di giri descritto in tabella è indicativo. L'applicazione va valutata in base al tipo d'impiego, il fattore di servizio e le condizioni di lavoro. Si consiglia di non superare l'angolo di avvolgimento consentito dalla cinghia.

The rpm indicated in the chart is approximate. The application must be considered according to the type of use, the service factor and the working conditions. It is not recommended to exceed the winding corner allowed by the belt.

45 T Tipo: 45TRP – 45 T Type: 45TRP
(con rullo in poliammide – with roller in polyamid)

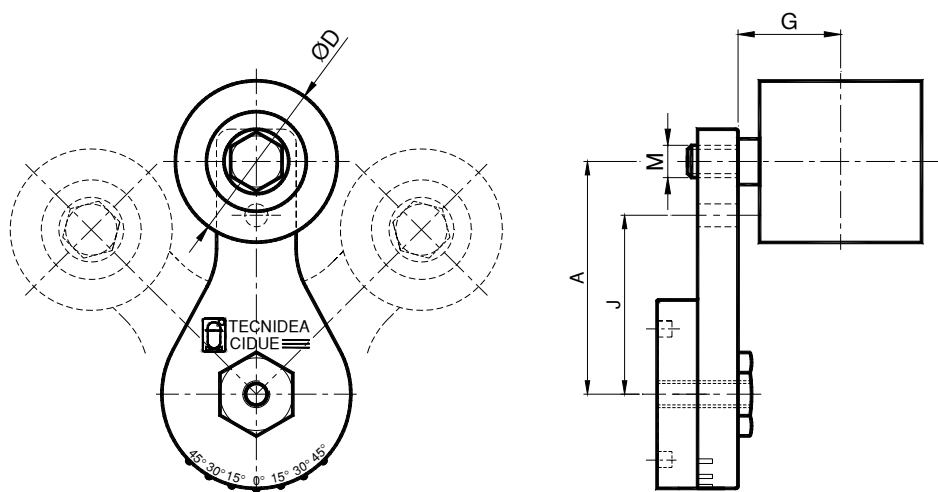

Il tenditore 45TRP è composto dall'elemento 45T e dal kit per tendicinghia RP. I valori di carico sono riportati a pag 06. Specificare nell'ordine il montaggio del kit sul foro A o J. In mancanza di specifiche richieste sarà fornito posizionato sul foro A.

The tensioner 45TRP is composed by the element 45T and the chaintensioner kit RP. The loading values are indicated at page 06. Specify in the order the assembly of the kit on the hole A or J. Failing specific requests, it will be supplied positioned on the hole A.

Cinghia Belt	45T + RP	45T		RP				
 Larghezza max Max width		 Pag. 06		 Pag. 27	ØD	G	M	
30	45T1RP1	45T 1-8	AS010900	RP 1T	RE011091	30	20.5	M 8
40	45T1RP2/3	45T 1-M10	AS010902	RP 2/3	RE011092	40	28.5	M10
55	45T1RP4	45T 1-M12	AS010904	RP 4	RE011094	60	38.0	M12
55	45T2RP4	45T 2-M12	AS010913	RP 4	RE011094	60	38.0	M12
85	45T2RP5	45T 2-M20	AS010920	RP 5	RE011096	80	54.0	M20

Verificare il lato di contatto del rullo sulla cinghia, rispettare i valori di avvolgimento consentiti. Nel caso di cinghie trapezoidali i rulli piani vanno montati sul dorso della cinghia, facendo attenzione ad eventuali fenomeni di snervamento delle fibre.

Verify the contact side of the roller on the belt, respect the allowed winding values. In case of trapezoidal belts, the plane rollers should be installed on the back of the belt, paying attention to possible events of fiber yielding.

45T Tipo: 45TRU – 45T Type: 45TRU
(con rullo in acciaio – with roller in steel)

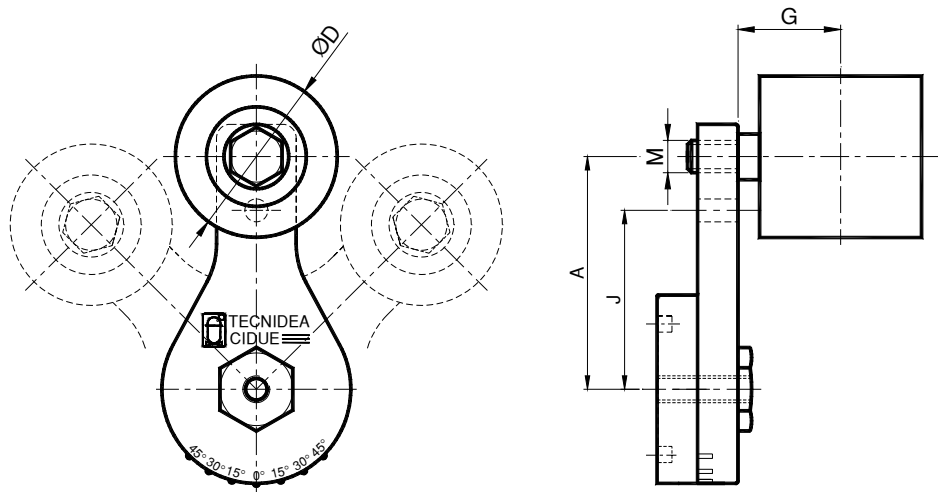

Il tenditore 45TRU è composto dall'elemento base 45T e dal kit per tendicinghia RU. I valori di carico sono riportati a pag 06. Specificare nell'ordine il montaggio del kit sul foro A o J. In mancanza di specifiche richieste sarà fornito posizionato sul foro A.

The tensioner 45TRU is composed by the element 45T and the chaintensioner kit RU. The loading values are indicated at page 06. Specify in the order the assembly of the kit on the hole A or J. Failing specific requests, it will be supplied positioned on the hole A.

Cinghia Belt	45T + RU	45T		RU				
		Pag. 06		Pag. 27		ØD	G	M
 Larghezza max Max width								
30	45T1RU1	45T 1-8	AS010900	RU 1T	AR070871	30	20.5	M 8
40	45T1RU2/3	45T 1-M10	AS010902	RU 2/3	AR070872	40	28.5	M10
55	45T1RU4	45T 1-M16	AS010907	RU 4	AR070874	60	38.0	M16
55	45T2RU4	45T 2-M16	AS010916	RU 4	AR070874	60	38.0	M16
85	45T2RU5	45T 2-M20	AS010920	RU 5	AR070876	80	54.0	M20

Verificare il lato di contatto del rullo sulla cinghia, rispettare i valori di avvolgimento consentiti. Nel caso di cinghie trapezoidali i rulli piani vanno montati sul dorso della cinghia, facendo attenzione ad eventuali fenomeni di snervamento delle fibre.

Verify the contact side of the roller on the belt, respect the allowed winding values. In case of trapezoidal belts, the plane rollers should be installed on the back of the belt, paying attention to possible events of fiber yielding.

Puleggia trapezoidale in ghisa – Tipo: **PQ** (Z-A-B)
V-Belt cast iron pulley – Type: **PQ** (Z-A-B)

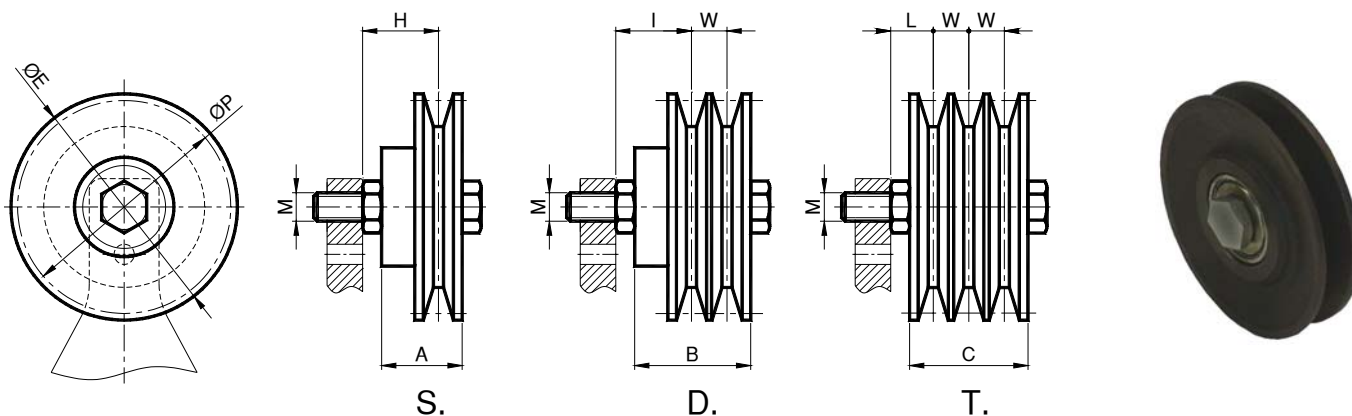

MATERIALI Puleggia in ghisa. Distanziali, cuscinetti e bulloneria in acciaio.
TRATTAMENTI Particolari metallici in acciaio zincato. Puleggia brunita o verniciata. Cuscinetti lubrificati.
IMPIEGO Puleggia per il tensionamento di cinghie trapezoidali.
Temperatura di lavoro della puleggia ≤100°C.

MATERIALS V-Belt pulley made of cast-iron. Spacers, bearings and bolts of made of steel.
TREATMENTS Metallic components made of zinc plated steel. The pulley is burnished or painted. Greased bearings.
USE Pulley for V-Belt, it is used for belt tensioning.
Operating temperature ≤100°C.

Tipo Type	S Cod. N°	D Cod. N°	T Cod. N°	Cinghia Belt	A	B	C	ØE	H	I	L	M	ØP	W	Peso Weight in Kg		
															S.	D.	T.
PQ 30-Z	AR071490	AR071500	AR071510	Z	24	35	40	67	24	23	16.5	M10	63	12	0.40	0.70	1.10
PQ 40-A	AR071492	AR071502	AR071512	A	34	45	50	95.6	33	28	19.5	M12	90	15	1.10	1.10	1.80
PQ 40-B	AR071494	AR071504		B	41	55		132	38.5	32.5		M12	125	19	1.90	2.8	
PQ 50-B			AR071514	B			63	132			26.5	M20	125	19			3.50

Esempio di applicazione / Application Example

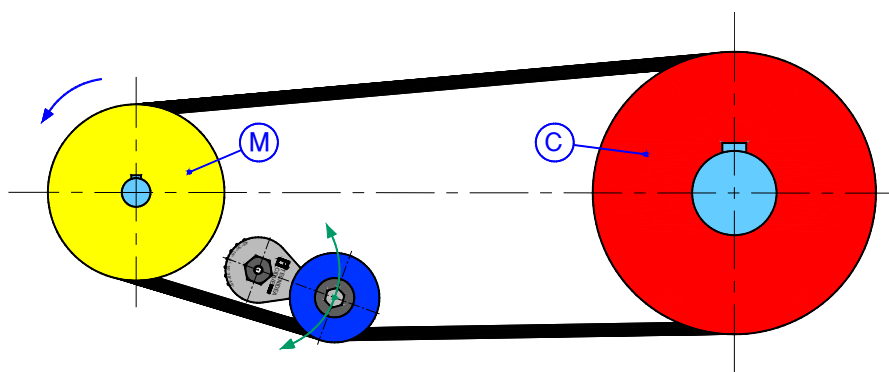

M: Puleggia motrice
Driving pulley
C: Puleggia condotta
Driven pulley

Il tendicinghia ove è possibile va sempre montato il più vicino possibile alla puleggia motrice con il verso in uscita come indicato in figura.

The belt tightener, where possible, should always be installed as closer as possible to the driving pulley with the direction in the exit, as illustrated in the picture.

45T Tipo: 45TPQ – 45T Type: 45TPQ

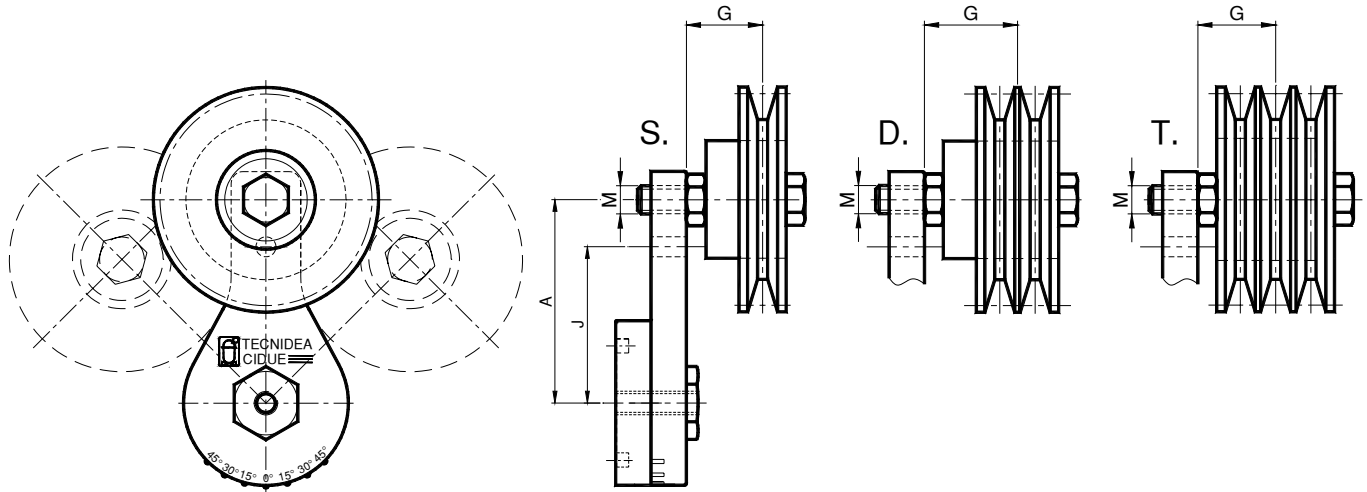

Il tenditore 45TPQ è composto dall'elemento base 45T e dal kit per tendicinghia PQ. I valori di carico sono riportati a pag 06. Specificare nell'ordine il montaggio del kit sul foro A o J. In mancanza di specifiche richieste sarà fornito posizionato sul foro A.

The tensioner 45TPQ is composed by the element 45T and the chaintensioner kit PQ. The loading values are indicated at page 06. Specify in the order the assembly of the kit on the hole A or J. Failing specific requests, it will be supplied positioned on the hole A.

Cinghia Belt	45T + PQ	45T		PQ			
		Pag. 06		Pag. 30		G	M
Tipo Type							
Z	45T1PQZS	45T 1-M10	AS010902	PQ 30-Z S	AR071490	24.0	M10
A	45T1PQAS	45T 1-M12	AS010904	PQ 40-A S	AR071492	33.0	M12
A	45T2PQAS	45T 2-M12	AS010913	PQ 40-A S	AR071492	33.0	M12
B	45T2PQBS	45T 2-M12	AS010913	PQ 40-B S	AR071494	38.5	M12
Z	45T1PQZD	45T 1-M10	AS010902	PQ 30-Z D	AR071500	29.0	M10
A	45T1PQAD	45T 1-M12	AS010904	PQ 40-A D	AR071502	35.7	M12
A	45T2PQAD	45T 2-M12	AS010913	PQ 40-A D	AR071502	35.7	M12
B	45T2PQBD	45T 2-M12	AS010913	PQ 40-B D	AR071504	42.0	M12
Z	45T1PQZT	45T 1-M10	AS010902	PQ 30-Z T	AR071510	28.5	M10
A	45T1PQAT	45T 1-M12	AS010904	PQ 40-A T	AR071512	34.5	M12
A	45T2PQAT	45T 2-M12	AS010913	PQ 40-A T	AR071512	34.5	M12
B	45T2PQBT	45T 2-M20	AS010920	PQ 50-B T	AR071514	45.5	M20

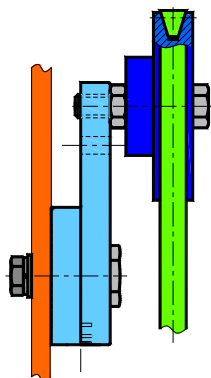

La cinghia deve avere la medesima forma e tipologia della puleggia, in modo che possano avere tra loro un accoppiamento perfetto.

The belt must have the same shape and type as the pulley, so that there can be a perfect coupling between them.

Tecnidea Cidue products:

TCZ **ARCO** C 2013
BREVETTATO - PATENED

ARCO

TCZ **BLU** C 2013
BREVETTATO - PATENED

BLU

TCZ **ASSO** C 2003

ASSO

TCZ **ARIA OLIO** C 2013
BREVETTATO - PATENED

ARIA OLIO

TCZ **+3KD** C 2013
BREVETTATO - PATENED

+3KD

TCZ **CAFRA /CHLÙ/REL** C 2013
BREVETTATO - PATENED

CAFRA

TCZ **CIAO** C 2004
BREVETTATO - PATENED

CIAO

TCZ **CRESA** C 2007
BREVETTATO - PATENED

CRESA

TCZ **PTC PTF** C 2013

PTC

TCZ **TB TEN BLOC** C 2013
BREVETTATO - PATENED

TEN BLOC

TCZ **TJ TEN JOY** C 2013

TEN JOY

TCZ **VIB** C 2007

VIB

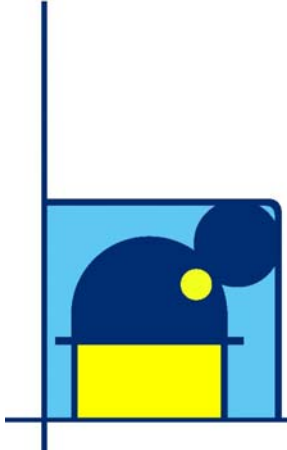

Tecnidea Cidue S.r.l.
Via Apollo XI, 12
37057 – San Giovanni Lupatoto (Verona) – Italy
Tel. 0039 (0)45 8750250 – Fax 0039 (0)45 8750288
sales@tecnideacidue.com
www.tecnideacidue.com

